



DS2100N

QUICK REFERENCE GUIDE

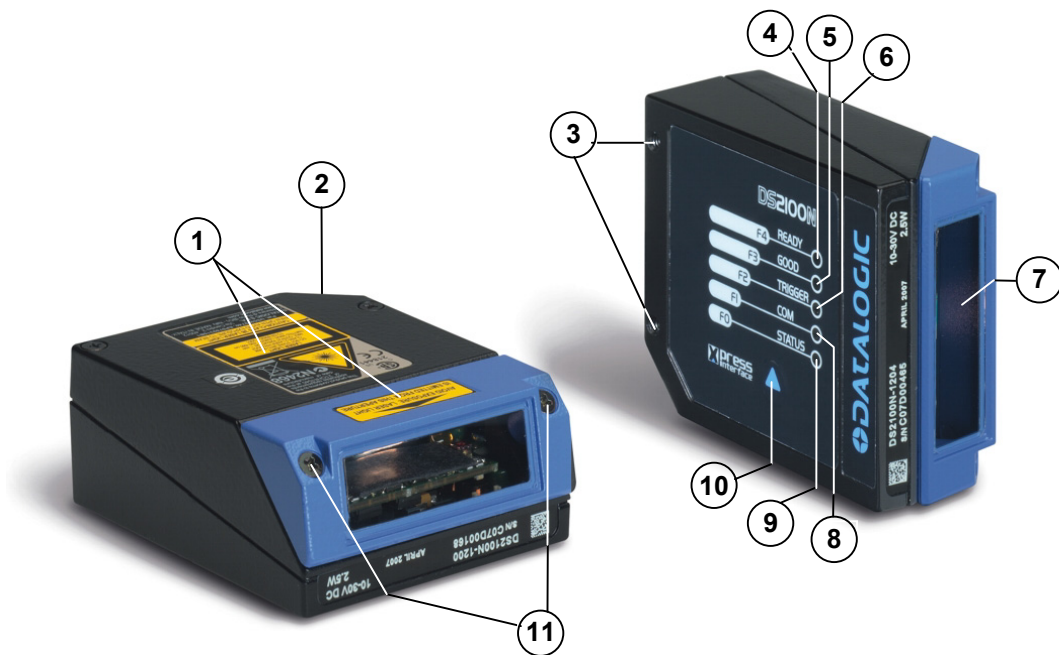

Figure A

- | | |
|-----------------------------------|----------------------------|
| ① Warning and Device Class Labels | ⑦ Laser Beam Output Window |
| ② "POWER ON" LED | ⑧ "COM" LED |
| ③ Mounting Holes | ⑨ "STATUS" LED |
| ④ "READY" LED | ⑩ Push Button |
| ⑤ "GOOD" LED | ⑪ Accessory Mounting Holes |
| ⑥ "TRIGGER" LED | |



NOTE

This manual illustrates a Stand Alone application. For other types of installations, such as ID-NET™, Pass-Through, Multiplexer Layout, etc. and for a complete scanner configuration using Genius™ configuration program, refer to the DS2100N Reference Manual available on the CD. This manual is also downloadable from the Web at www.automation.datalogic.com/ds2100n.

UPDATES AND LANGUAGE AVAILABILITY

UK/US

The latest drivers and documentation updates for this product are available on Internet.
Log on to: www.automation.datalogic.com

I

Su Internet sono disponibili le versioni aggiornate di driver e documentazione di questo prodotto. Questo manuale è disponibile anche nella versione italiana.
Collegarsi a: www.automation.datalogic.com

F

Les versions mises à jour de drivers et documentation de ce produit sont disponibles sur Internet. Ce manuel est aussi disponible en version française.
Cliquez sur : www.automation.datalogic.com

D

Im Internet finden Sie die aktuellsten Versionen der Treiber und Dokumentation von diesem Produkt. Die deutschsprachige Version dieses Handbuches ist auch verfügbar.
Adresse : www.automation.datalogic.com

E

En Internet están disponibles las versiones actualizadas de los drivers y documentación de este producto.
También está disponible la versión en español de este manual.
Dirección Internet : www.automation.datalogic.com

SERVICES AND SUPPORT

Datalogic provides several services as well as technical support through its website. Log on to www.automation.datalogic.com and click on the [links](#) indicated for further information including:

- **PRODUCTS**

Search through the links to arrive at your product page where you can download specific **Manuals** and **Software & Utilities** including:

- **Genius™** a utility program, which allows device configuration using a PC. It provides RS232 interface configuration.

- **SERVICES & SUPPORT**

- **Datalogic Services** - Warranty Extensions and Maintenance Agreements

- **Authorised Repair Centres**

- **CONTACT US**

E-mail form and listing of Datalogic Subsidiaries

STEP 1 – CONNECT THE SYSTEM

To connect the system in a Stand Alone configuration, you need the hardware indicated in Figure 1.

In this layout the data is transmitted to the Host on the main serial interface.

In Local Echo communication mode, data is transmitted on the RS232 auxiliary interface independently from the main interface selection.

When On-Line Operating mode is used, the scanner is activated by an External Trigger (photoelectric sensor) when the object enters its reading zone.

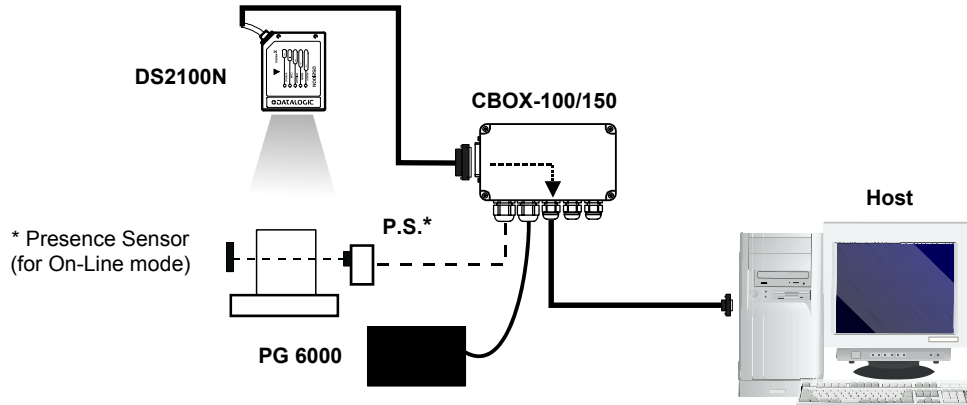

Figure 1 – DS2100N in Stand Alone Layout

C-BOX 100/150 Pinout for DS2100N

The table below gives the pinout of the C-BOX 100/150 terminal block connectors. Use this pinout when the DS2100N reader is connected by means of the C-BOX 100/150:

C-BOX 100/150 Terminal Block Connectors				
Power		Outputs		
1, 3, 5	VS	21	OUT 1+	
2, 4, 6	GND	22	OUT 1-	
7, 8	EARTH GROUND	23	OUT 2+	
20, 40	Reserved	24	OUT 2-	
Inputs		25	NC	
27	EXT TRIG A (polarity insensitive)	26	NC	
28	EXT TRIG B (polarity insensitive)	Auxiliary Interface		
29	NC	35	TX AUX	
30	IN2-	37	RX AUX	
31, 33	NC	ID-NET™		
32, 34	NC	36	ID-NET-	
39	GND	38	ID-NET+	
Main Interface				
	RS232	RS485 Full-Duplex	RS485 Half-Duplex	20 mA C.L. (with INT-30 only)
11, 15	TX 232	TX 485+	RTX 485+	see INT-30 instructions
12, 16	RTS 232	TX 485-	RTX 485-	
17	RX 232	*RX 485+		
18	CTS 232	*RX 485-		
10, 14, 19	SGND	SGND	SGND	
9, 13		RS485 Cable Shield	RS485 Cable Shield	

* Do not leave floating, see Reference Manual for connection details.



CAUTION

Do not connect GND and SGND to different (external) ground references. GND and SGND are internally connected through filtering circuitry which can be permanently damaged if subjected to voltage drops over 0.8 Vdc.

STEP 2 – MOUNTING AND POSITIONING THE SYSTEM

1. To mount the DS2100N, use the mounting bracket to obtain the most suitable position for the reader as shown in the figures below.

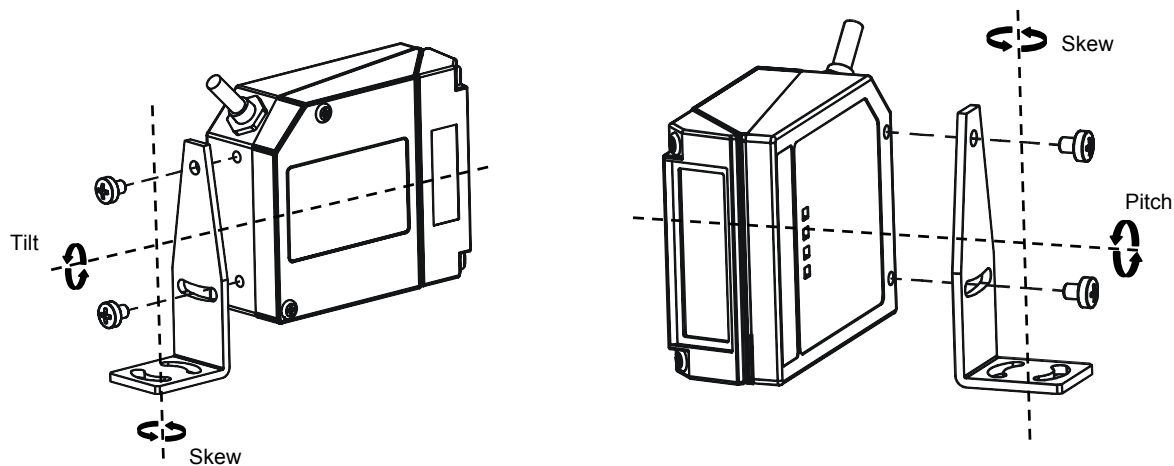

Figure 2 - Positioning with Mounting Bracket

2. When mounting the DS2100N take into consideration these three ideal label position angles: **Pitch 0°**, **Skew 10° to 30°** and **Tilt 0°**.

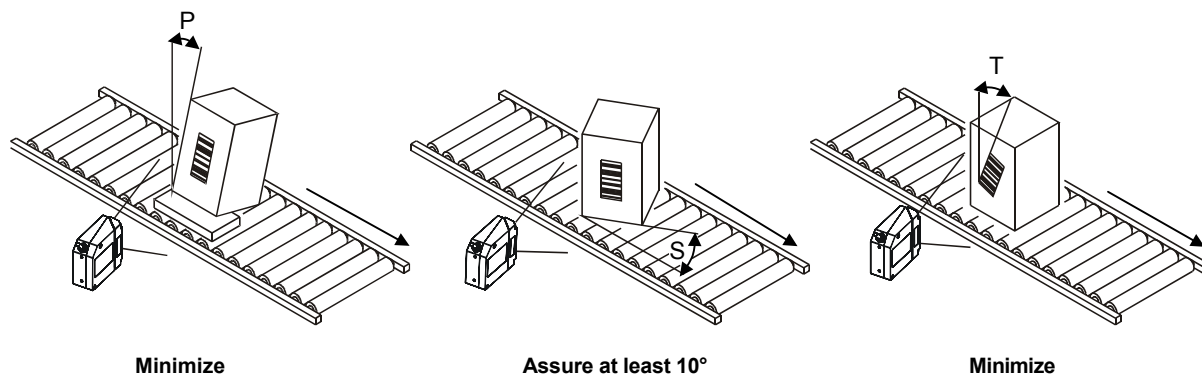

Figure 3 – Pitch, Skew and Tilt Angles

3. Refer to the Reading Diagrams in the Appendix of this Quick Reference Guide to decide the distance your scanner should be positioned at.

STEP 3 – X-PRESS™ CONFIGURATION

X-PRESS™ is the intuitive Human Machine Interface designed to improve ease of installation and maintenance.

Status and diagnostic information are clearly presented by means of the five colored LEDs, whereas the single push button gives immediate access to the following relevant functions:

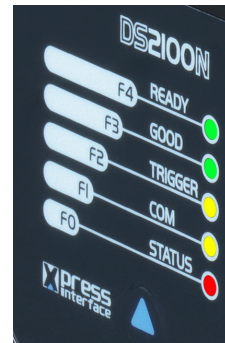

- *Test Mode (F1)* with bar graph visualization to check static reading performance
- *AutoLearn (F2)* to self-detect and auto-configure for reading unknown barcodes (by type and length)
- *AutoSetup (F3)* to self-optimize and auto-configure reading performance in demanding applications



NOTE

If using the OM2000N accessory, when entering the X-PRESS™ interface, the Oscillating Mirror remains in the default fixed position (-15°) in order to make barcode reading easier while performing the X-PRESS™ functions.

The colors and meaning of the five LEDs are illustrated in the following table:

F4	READY (green)	This LED indicates the device is ready to operate.
F3	GOOD (green)	This LED confirms successful reading.
F2	TRIGGER (yellow)	This LED indicates the status of the reading phase.
F1	COM (yellow)	This LED indicates active communication on main serial port.
F0	STATUS (red)	This LED indicates a NO READ result.

During the reader startup (reset or restart phase), all the LEDs blink for one second.

On the back of the reader near the cable, the “POWER ON” LED indicates the laser scanner is correctly powered.

AUTO LEARN

If you are configuring your scanner using X-PRESS™, you must start with the *Auto Learn* procedure.

1. Enter the *Auto Learn* function (F2) by pressing the X-PRESS™ push button.
2. Hold the push button pressed until the F2 LED is on.
3. Release the button to enter the *Auto Learn* function.

Once entered, the reader starts a procedure to automatically detect and recognize barcodes (by type and length), which are presented to it (*). The laser turns on and the TRIGGER LED blinks to indicate the ongoing process.

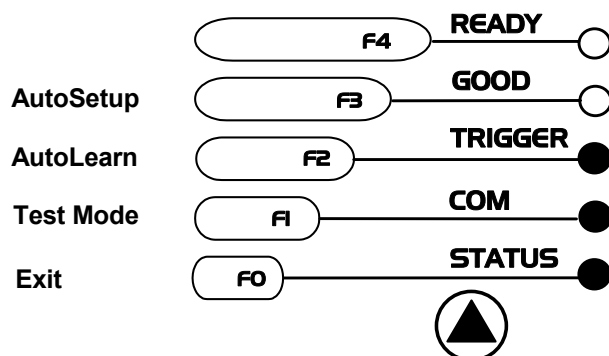

The procedure is as follows:

- A) **place** the desired barcode on the scanline.
- B) **wait** until the TRIGGER LED stays steady on (indicating the reader has detected the barcode).
- C) **repeat**, if needed, the above two steps to program up to 10 different barcodes (either by length or by symbology). If more than one barcode is detected, the Multi Label mode is enabled (refer to the “2000 Family Software Configuration Parameter Guide” Help file).

Figure 4 – X-PRESS™ Interface: Auto Learn Function

4. **Exit** the process by pressing the X-PRESS™ push button once. The scanner will restart at the end of the process, and then the detected barcodes are automatically configured in scanner memory.



NOTE *If the barcode cannot be read because of low contrast or excessive ambient light, you can perform the AutoSetup function to optimize the optical parameters. Then you can perform AutoLearn to recognize the barcode symbology.*

AUTO SETUP (OPTIONAL)

At the end of the *Auto Learn* procedure, you can perform the *Auto Setup* procedure to set up the reading parameters.

1. Enter the *Auto Setup* function (F3) by pressing the X-PRESS™ push button.
2. Hold the push button pressed until the F3 LED is on.
3. Release the button to enter the *Auto Setup* function.
4. Once entered, if a barcode label is positioned in front of the scanline, the scanner automatically performs the optimal setup of the reading parameters for that specific barcode.

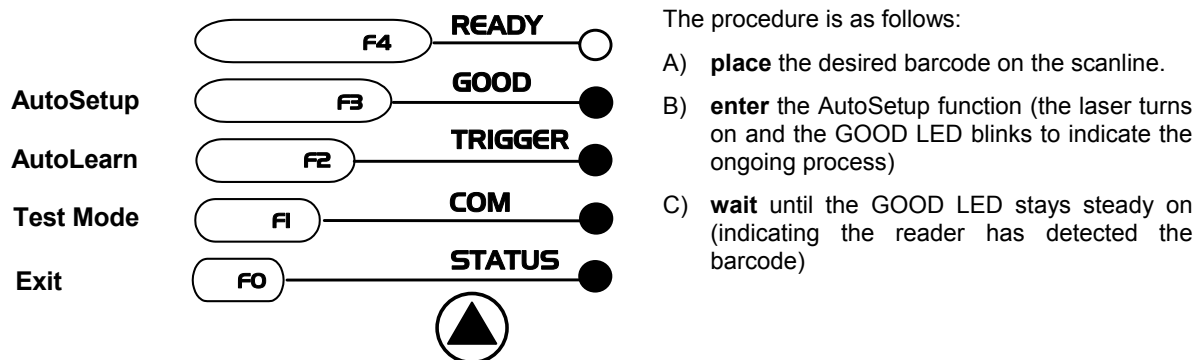



Figure 5 – X-PRESS™ Interface: Auto Setup Function

This procedure ends either when the barcode is successfully decoded or after a timeout of about 7 (seven) seconds. The scanner will restart at the end of the process, and then the optimized reading parameters for that barcode are automatically configured in scanner memory.



NOTE *If your application has been configured using X-PRESS™, go to STEP 5.*

STEP 4 – INSTALLING GENIUS™ CONFIGURATION PROGRAM

Genius™ is a Datalogic scanner configuration tool providing several important advantages:

- Wizard approach for low skilled users;
- Multi-language version;
- Defined configuration directly stored in the reader;
- Communication protocol independent from the physical interface allowing to consider the reader as a remote object to be configured and monitored.

To install Genius™, turn on the PC that will be used for the configuration, running Windows 98, 2000/NT or XP, then insert the Genius™ CD-ROM, wait for the CD to autorun and follow the installation procedure.

This configuration procedure assumes scanner connection to a C-BOX 100/150. Genius™, running on a laptop computer, is connected to the scanner auxiliary port through the C-BOX 100/150 9-pin connector.

WIZARD FOR QUICK READER SETUP

After installing the Genius™ software program the following window appears asking the user to choose the desired configuration level.

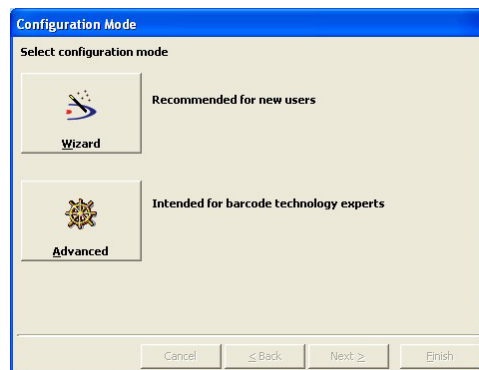
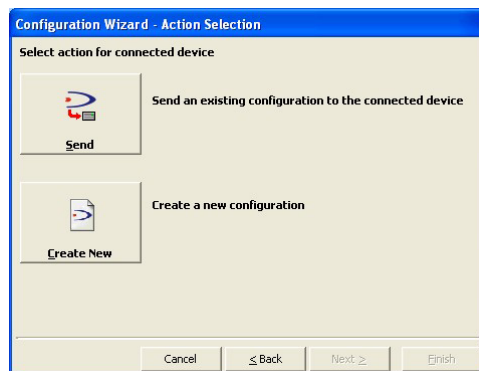

Figure 6 - Genius™ Wizard Opening Window

The Wizard option is advised to low skilled users, since it shows a step-by-step scanner configuration.

1. Select the *Create a new configuration* button.



You will be guided through the configuration being asked to define the following parameters:

a. Barcode selection and definition

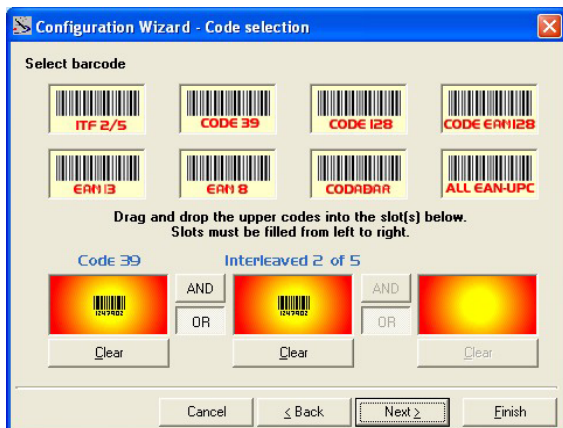

b. Operating mode selection and definition

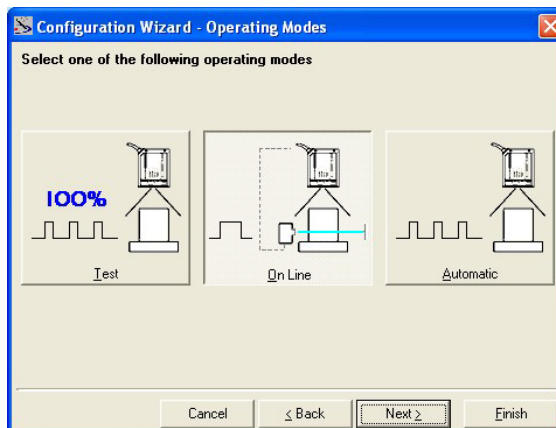

c. Digital Outputs configuration

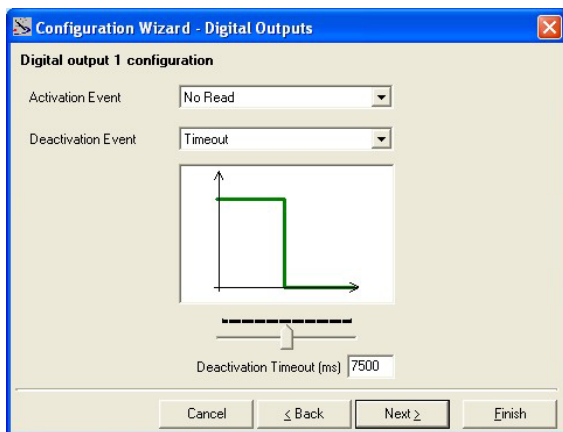

d. Hardware interface selection

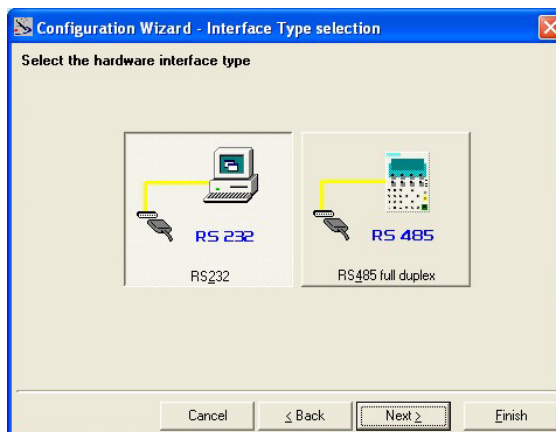

e. Output data format configuration

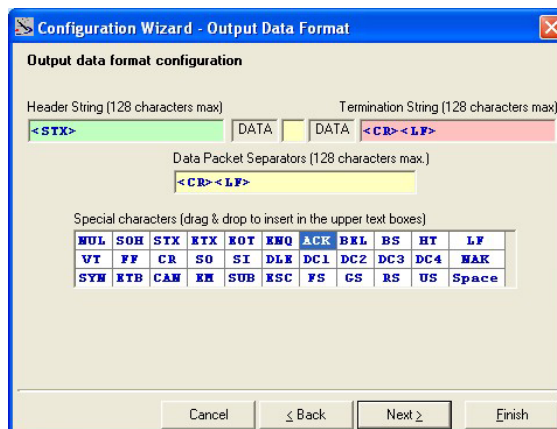

The **On Line** operating Mode requires the reader to be connected to an external Presence Sensor using EXT TRIG/PS A and EXT TRIG/PS B inputs.

The **Automatic** operating mode does not require connection to an external Presence Sensor. When working in this mode the reader is continuously scanning, while the reading phase is activated each time a barcode enters the reader reading zone. The reader stops reading after an N number of scans without a code. Barcode characters are transmitted on the serial interface. In case of a failed reading phase no message is sent to the host computer.

2. After defining the parameter values the following window appears allowing to complete the reader configuration as follows:
 - Saving the configuration to disk;
 - Switching to Advanced mode;
 - Sending the configuration to the scanner.



3. After sending the configuration to the scanner you have completed the configuration process.



4. By clicking Finish, the System Information window will be displayed with specific information concerning the scanner.

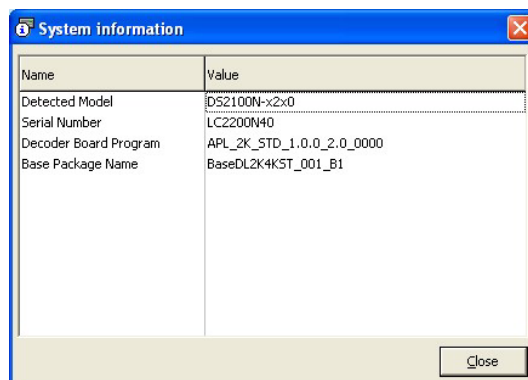

STEP 5 – TEST MODE

Use a code suitable to your application to test the system. Alternatively, you can use the Datalogic Test Chart (Code 39, Code Interleaved 2/5).

1. Enter the *Test mode* function (F1) by pressing the X-PRESS™ push button.
2. Hold the push button pressed until the F1 LED is on.
3. Release the button to enter the *Test mode* function.
Once entered, the Bar Graph on the five LEDs is activated and if the scanner starts reading barcodes the Bar-Graph shows the Good Read Rate. In case of no read condition, only the STATUS LED is on and blinks.

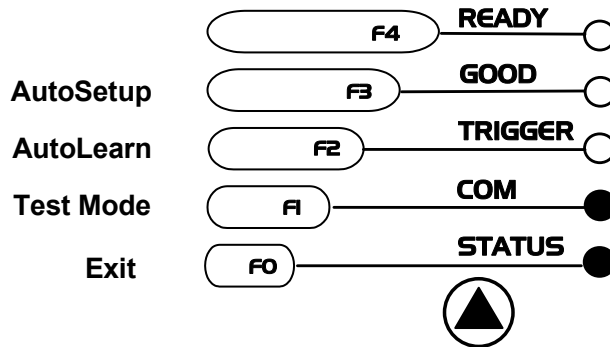

Figure 7 – X-PRESS™ Interface: Test Mode Function

4. To exit the Test Mode, press the X-PRESS™ push button once.



NOTE

By default, the Test Mode exits automatically after two minutes.

ADVANCED SCANNER CONFIGURATION

For further details on advanced product configuration, refer to the complete Reference Manual on the installation CD-ROM or downloadable from the web site through this link: www.automation.datalogic.com/ds2100n.

The following are alternative or advanced scanner configuration methods:

HOST MODE PROGRAMMING

The scanner can also be configured from a host computer using the Host Mode programming procedure, by commands via the serial interface. See the Host Mode Programming file on the CD-ROM.

ADVANCED GENIUS™ CONFIGURATION

The ADVANCED selection available when starting the Genius™ program is addressed to expert users being able to complete a detailed scanner configuration. By choosing this option it is possible either to start a new scanner configuration or to open and modify an old one. The desired parameters can be defined in the following window, similar to the MS Explorer:

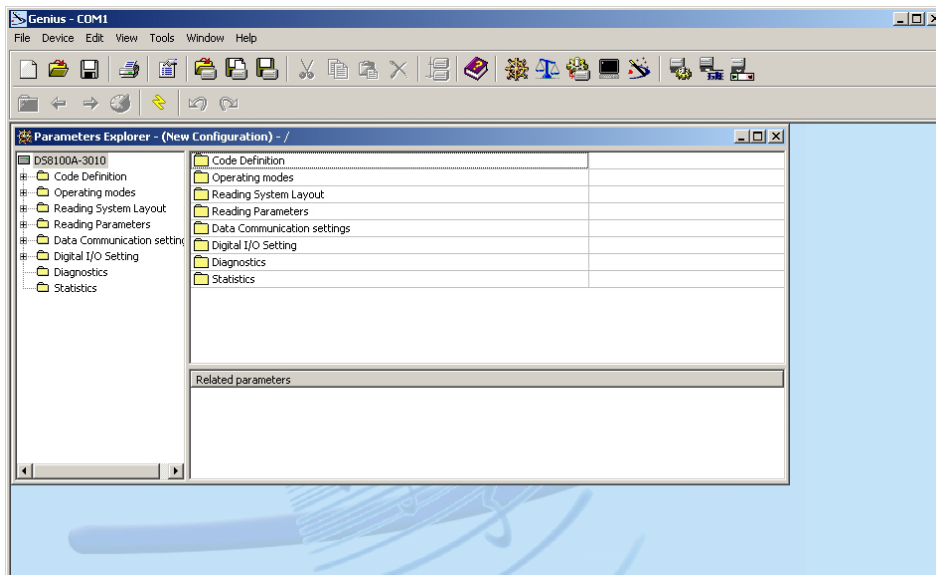

Figure 8 - Genius™ Parameter Explorer Window

ALTERNATIVE LAYOUTS

- The ID-NET™ is a built-in high-speed interface dedicated for high-speed scanner interconnection. ID-NET™ is in addition to the Main and Auxiliary serial interfaces.
If you need to install an ID-NET™ network refer to the DS2100N Reference Manual.
The scanner can also be configured by reading programming barcodes. See the ID-NET™ Setup Procedure Using Programming Barcodes printable from the CD-ROM.
- If you need to install a Pass-Through network refer to the DS2100N Reference Manual.
- If you need to install a Multiplexer network refer to the DS2100N Reference Manual.
- If you need to install an RS232 Master/Slave (for backward compatibility) refer to the DS2100N Reference Manual.

APPENDIX

READING DIAGRAMMS

DS2100N-1200 (Standard Resolution, 500 scans/s)

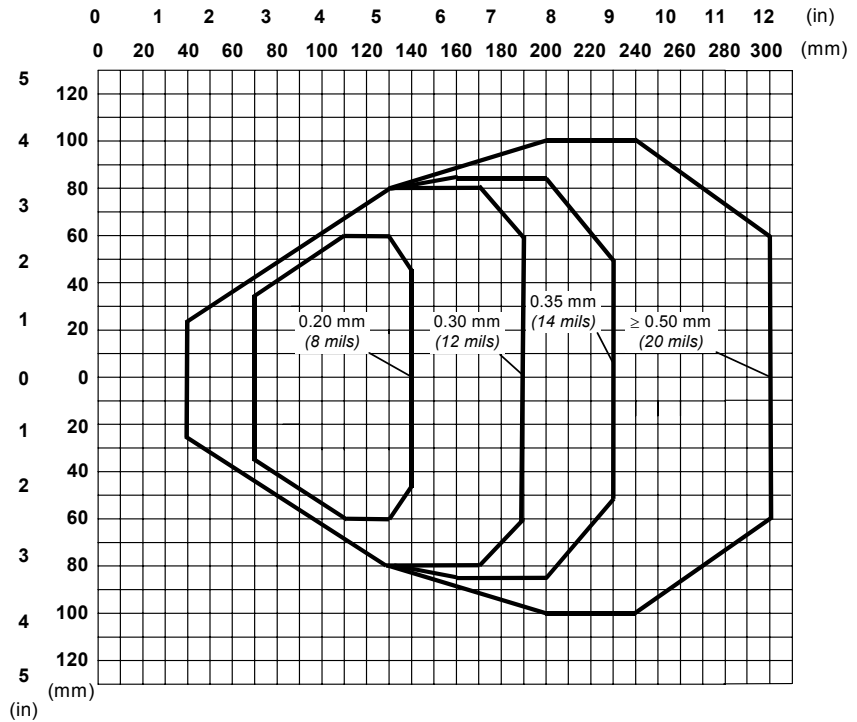

CONDITIONS

Optic Version = Linear
 Code = Interleaved 2/5 or Code 39
 PCS = 0.90
 Pitch angle = 0°
 Skew angle = 15°
 Tilt angle = 0°
 *Reading Conditions = Standard

* Parameter selectable in Genius

DS2100N-2200 (High resolution, 500 scans/s)

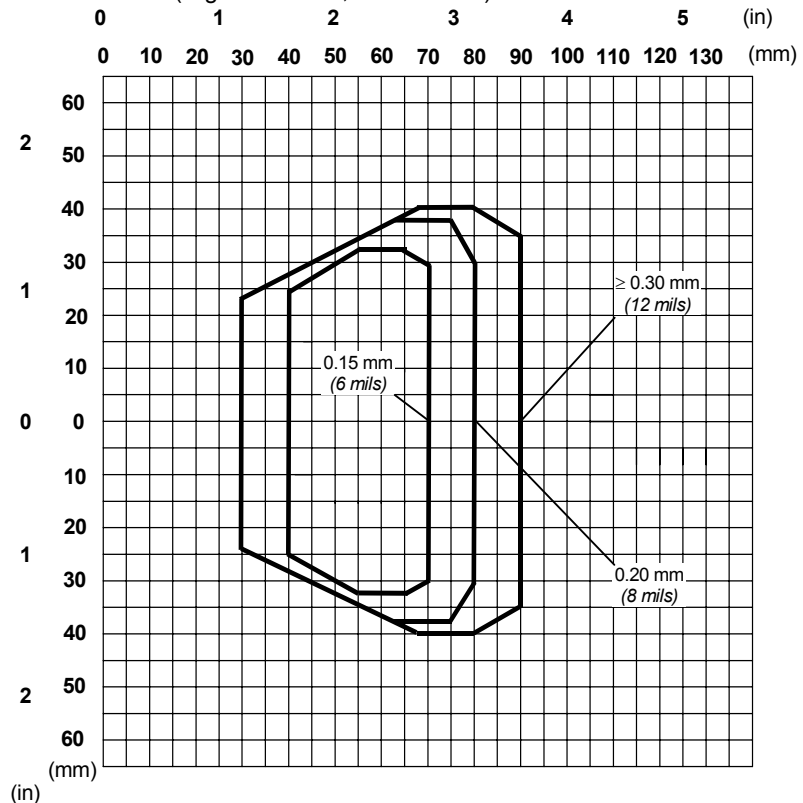

CONDITIONS

Optic Version = Linear
 Code = Interleaved 2/5 or Code 39
 PCS = 0.90
 Pitch angle = 0°
 Skew angle = 15°
 Tilt angle = 0°
 *Reading Conditions = Standard

* Parameter selectable in Genius

DS2100N-1204 High Performance (Standard resolution, 1000 scan/s)

CONDITIONS

Optic Version = Linear
 Code = Interleaved 2/5 or Code 39
 PCS = 0.90
 Pitch angle = 0°
 Skew angle = 15°
 Tilt angle = 0°
 *Code Resolution:
 High - for 0.30 mm (12 mils) codes and smaller
 Standard - for 0.50 mm (20 mils) codes and greater
 *Reading Conditions = Standard

* Parameter selectable in Genius

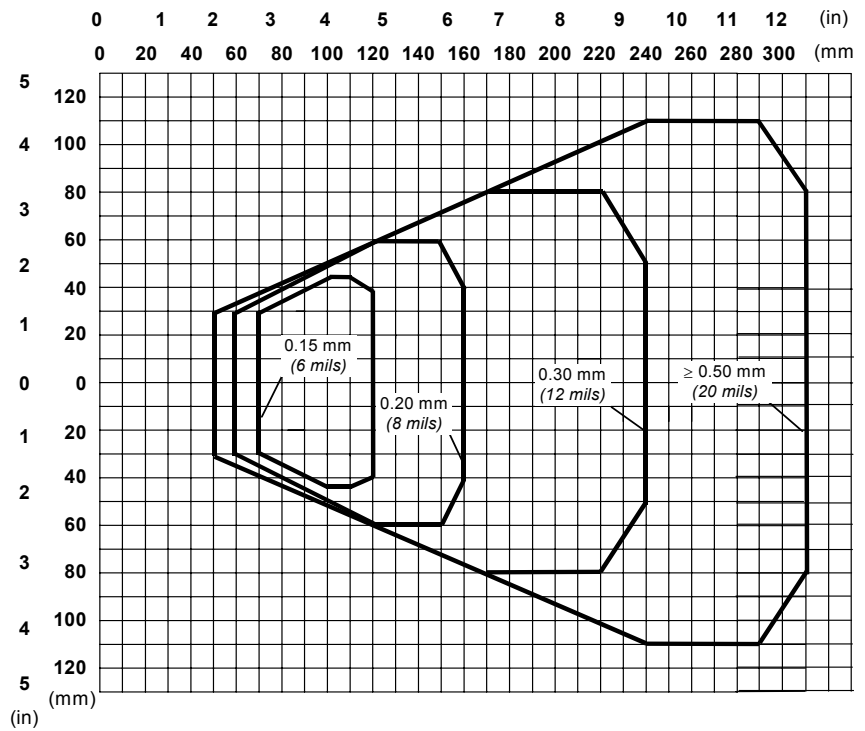

DS2100N-2204 High Performance - (High Resolution, 1000 scans/s)

CONDITIONS

Optic Version = Linear
 Code = Interleaved 2/5 or Code 39
 PCS = 0.90
 Pitch angle = 0°
 Skew angle = 15°
 Tilt angle = 0°
 *Code Resolution:
 High - for 0.15 mm (6 mils) codes and smaller
 Standard - for 0.20 mm (8 mils) codes
 *Reading Conditions = Standard

* Parameter selectable in Genius

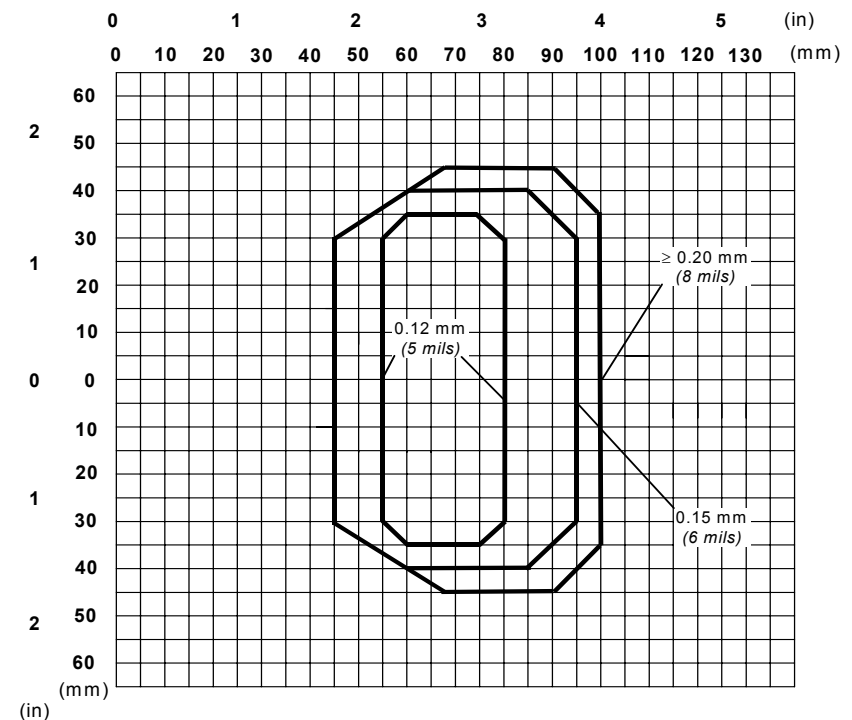

READING PERFORMANCE

Version	Reading Distance	Max Code Resolution mm (mils)	Speed scans/s
1XX0	40 mm (1.6 in) - 300 mm (11.8 in) on 0.50 mm (20 mils) codes	0.20 (8)	500 to 800
1XX4	50 mm (1.8 in) - 310 mm (11.8 in) on 0.50 mm (20 mils) codes	0.20 (8)	800 to 1000
2XX0	30 mm (1.2 in) - 90 mm (3.5 in) on 0.30 mm (12 mils) codes	0.15 (6)	500 to 800
2XX4	45 mm (1.8 in) - 100 mm (3.9 in) on 0.20 mm (8 mils) codes	0.12 (5)	800 to 1000

TECHNICAL FEATURES

ELECTRICAL FEATURES	
Power Supply	10-30 Vdc
Power Consumption	Model XXX0: 3.5 W Model XXX4: 5 W
Main Serial Interfaces	Programmable: RS232, RS485 FD and HD
Baud Rate	1200 to 115200
Auxiliary Interface	RS232
Baud Rate	1200 to 115200
ID-NET™ Interface	RS485 Half Duplex
Baud Rate	Up to 1Mbaud
Inputs	
External Trigger	Optocoupled, polarity insensitive
IN2	Not-optocoupled NPN only
Voltage	Ext. Trig.: 5 to 30 Vdc IN2: (VS -5) to 0 Vdc
Current Consumption	12 mA max.
Pulse Rate	2 kHz max.
Pulse Duration	500 μs min.
Outputs	
OUT1, OUT2	Optocoupled
V_{CE}	30 Vdc max.
Collector Current	40 mA continuous max.; 130 mA pulsed max.
V_{CE} Saturation	1V at 10 mA max.
Power Dissipation	80 mW max. at 45 °C (ambient temperature)
OPTICAL FEATURES	
Light Source	Semiconductor laser diode
Wavelength	In the range 630 to 680 nm
Safety Class	Class 2 – EN 60825-1; CDRH
USER INTERFACE	
LED Indicators	Ready, Good, Trigger, Com, Status, Power On
Multi-function Key	X-PRESS™ button
PHYSICAL FEATURES	
Dimensions	68 x 84 x 34 mm (2.68 x 3.31 x 1.34 in)
Weight	330 g (11.6 oz)
ENVIRONMENTAL FEATURES	
Operating Temperature ①	0° to +45 °C (+32° to +113 °F)
Storage Temperature	-20° to +70 °C (-4° to +158 °F)
Humidity max.	90% non condensing
Vibration Resistance EN 60068-2-6	14 mm @ 2 to 10 Hz; 1.5 mm @ 13 to 55 Hz; 2 g @ 70 to 200 Hz; 2 hours on each axis
Bump Resistance EN 60068-2-29	30 g; 6 ms; 5000 shocks on each axis
Shock Resistance EN 60068-2-27	30 g; 11 ms; 3 shocks on each axis
Protection Class	IP65

① If the reader is used in high temperature environments (over 40 °C), it is advised the use of the Beam Shutter (see the Genius™ configuration program) and/or a thermal conductive support (such as the metal bracket provided).

MECHANICAL INSTALLATION

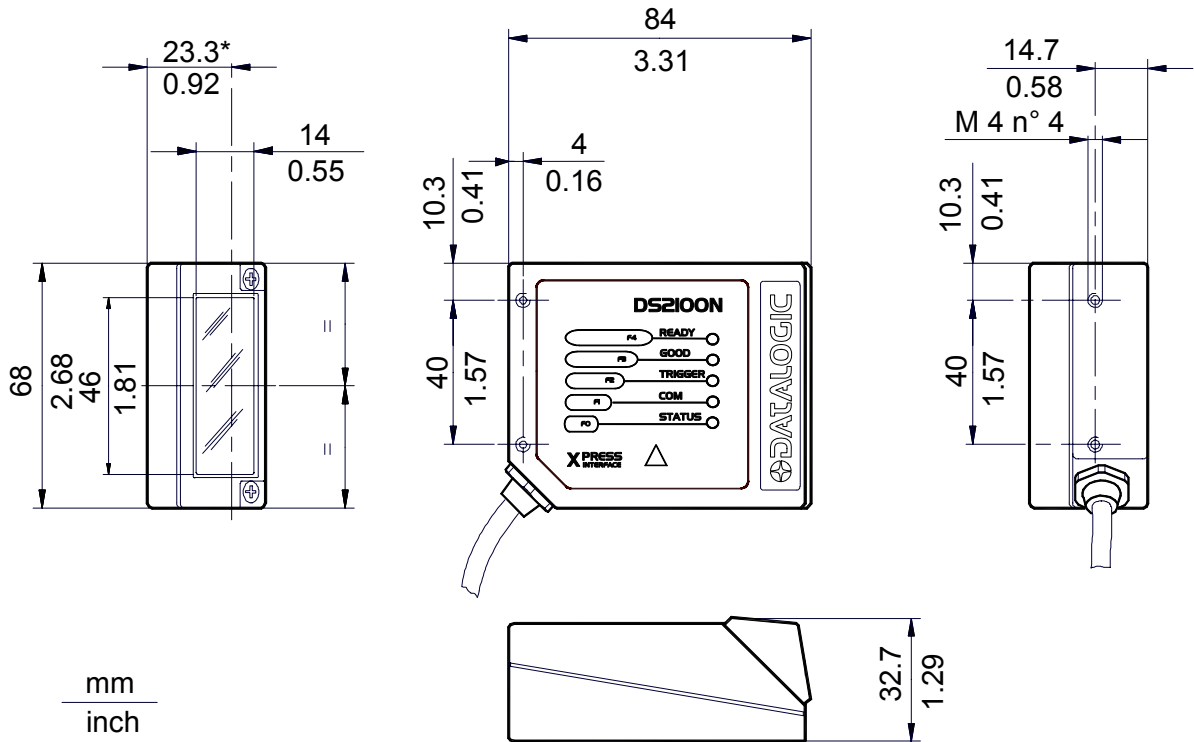

* The quote refers to the scan line

Figure 9 – DS2100N Overall Dimensions

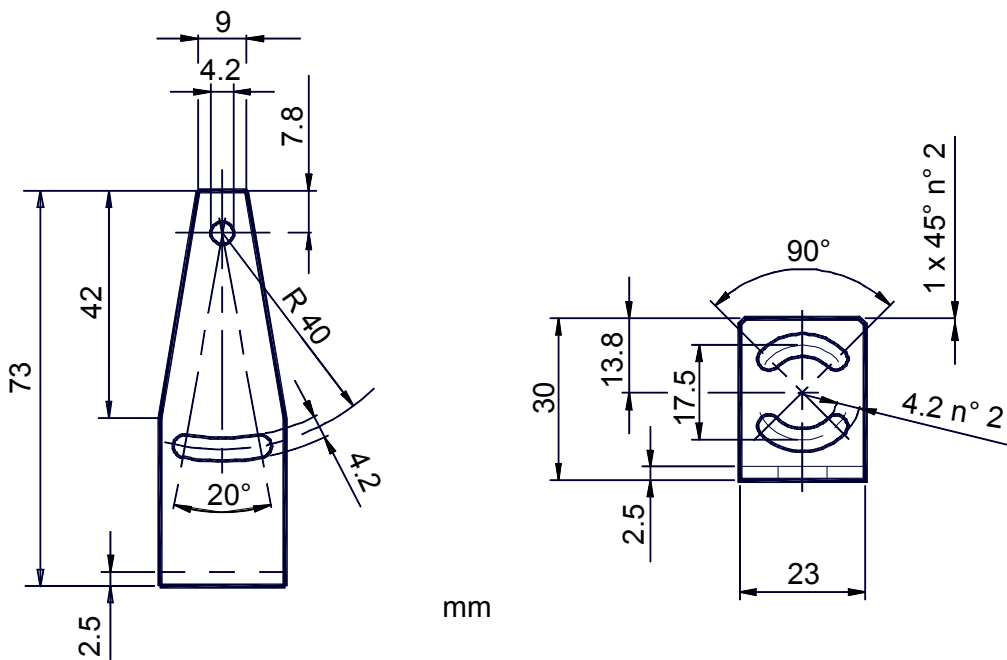

Figure 10 – Mounting Bracket Overall Dimensions

PATENTS

This product is covered by one or more of the following patents:

U.S. patent: 5,992,740
 European patent: 789,315 B1

COMPLIANCE

LASER SAFETY

The scanner is classified as a Class 2 laser product according to EN 60825-1 regulations and as a Class II laser product according to CDRH regulations.

Disconnect the power supply when opening the device during maintenance or installation to avoid exposure to hazardous laser light.

There is a safety device, which allows the laser to be switched on only if the motor is rotating above the threshold for its correct scanning speed.

The laser beam can be switched off through a software command (see also the Genius Help On Line).

The laser diode used in this device is classified as a class 3B laser product according to EN 60825-1 regulations and as a Class IIIb laser product according to CDRH regulations.

Any violation of the optic parts in particular can cause radiation up to the maximum level of the laser diode (35 mW at 630 to 680 nm).

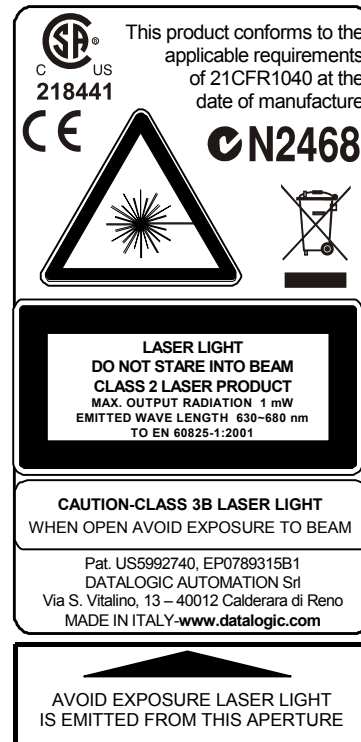

Figure 11 - Warning and Device Class Labels

POWER SUPPLY

This product is intended to be installed by Qualified Personnel only.

This accessory device is intended to be supplied by a UL Listed or CSA Certified Power Unit with «Class 2» or LPS power source, which supplies power directly to the scanner via the 25-pin connector.

CE COMPLIANCE

Warning: This is a Class A product. In a domestic environment this product may cause radio interference in which case the user may be required to take adequate measures.

Datalogic Automation S.r.l.
Via S. Vitalino 13
40012 - Lippo di Calderara
Bologna - Italy

dichiara che
 declares that the
 déclare que le
 bescheinigt, daß das Gerät
 declare que el

DS2100N Laser Scanner; e tutti i suoi modelli
 and all its models
 et tous ses modèles
 und seine Modelle
 y todos sus modelos

sono conformi alle Direttive del Consiglio Europeo sottoelencate:
 are in conformity with the requirements of the European Council Directives listed below:
 sont conformes aux spécifications des Directives de l'Union Européenne ci-dessous:
 der nachstehend angeführten Direktiven des Europäischen Rats:
 cumple con los requisitos de las Directivas del Consejo Europeo, según la lista siguiente:

89/336/EEC EMC Directive	e	92/31/EEC, 93/68/EEC	emendamenti successivi
	and		further amendments
	et		ses successifs amendements
	und		späteren Abänderungen
	y		sucesivas enmiendas

Basate sulle legislazioni degli Stati membri in relazione alla compatibilità elettromagnetica ed alla sicurezza dei prodotti.
 On the approximation of the laws of Member States relating to electromagnetic compatibility and product safety.
 Basée sur la législation des Etats membres relative à la compatibilité électromagnétique et à la sécurité des produits.
 Über die Annäherung der Gesetze der Mitgliedsstaaten in bezug auf elektromagnetische Verträglichkeit und Produktsicherheit entsprechen.
 Basado en la aproximación de las leyes de los Países Miembros respecto a la compatibilidad electromagnética y las Medidas de seguridad relativas al producto.

Questa dichiarazione è basata sulla conformità dei prodotti alle norme seguenti:
 This declaration is based upon compliance of the products to the following standards:
 Cette déclaration repose sur la conformité des produits aux normes suivantes:
 Diese Erklärung basiert darauf, daß das Produkt den folgenden Normen entspricht:
 Esta declaración se basa en el cumplimiento de los productos con las siguientes normas:

EN 55022 (Class A ITE), August 1994:
Amendment A1 (Class A ITE), October 2000:

LIMITS AND METHODS OF MEASUREMENTS OF RADIO DISTURBANCE
 CHARACTERISTICS OF INFORMATION TECHNOLOGY EQUIPMENT

EN 61000-6-2, October 2001:

ELECTROMAGNETIC COMPATIBILITY (EMC)
 PART 6-2: GENERIC STANDARDS - IMMUNITY FOR INDUSTRIAL
 ENVIRONMENTS

Lippo di Calderara, April 2nd, 2007

Lorenzo Girotti
 Product & Process Quality Manager

