

Installation Guide

Uninterruptible Power Supply

SNMP / WEB ADAPTER

P/N 1024748 3-ph SNMP/Web plug-in adapter

P/N 1024921 3-ph SNMP/Web plug-in adap.w/MODB.RS485

P/N 1024747 1-ph SNMP/Web plug-in adapter

P/N 1024746 SP SNMP/Web plug-in adapter

GE Consumer & Industrial SA

General Electric Company
CH - 6595 Riazzino (Locarno)
Switzerland

T +41 (0)91 / 850 51 51

F +41 (0)91 / 850 52 52

www.gepowerquality.com



imagination at work



Model: 3-ph SNMP/Web plug-in adapter
 3-ph SNMP/Web plug-in adap.w/MODB.RS485
 1-ph SNMP/Web plug-in adapter
 SP SNMP/Web plug-in adapter

Date of issue: 10.10.2012

File name: GE_UPS_ISG_CNT_SNM_BAS_CRD_1GB_V020

Revision: 2.0

Identification No. P/N 1024748
 P/N 1024921
 P/N 1024747
 P/N 1024746

Up-dating		
Revision	Concerns	Date
2.0	New SNMP/Web Adapter	10.10.2012

COPYRIGHT © 2012 by GE Consumer & Industrial SA

All rights reserved.

The information contained in this publication is intended solely for the purposes indicated.

The present publication and any other documentation supplied with the UPS system is not to be reproduced, either in part or in its entirety, without the prior written consent of **GE Digital Energy**.

The illustrations and plans describing the equipment are intended as general reference only and are not necessarily complete in every detail.

The content of this publication may be subject to modification without prior notice.

Dear Customer,

We thank you for selecting our products and are pleased to count you amongst our very valued customers at **GE Digital Energy**.

We trust that the use of the **SNMP/Web Adapters** for our Uninterruptible Power Supply systems, developed and produced to the highest standards of quality, will give you complete satisfaction.

Please read carefully the *Installation Guide*, which contains all the necessary information about the installation of the *SNMP/Web adapters*.

Thank you for choosing **GE Digital Energy** !

Distributed by:

Your service contact:



GE Digital Energy
General Electric Company
CH - 6595 Riazzino (Locarno)
Switzerland

Table of contents

Page

1	SAFETY RULES	5
1.1	WARNINGS AND CAUTIONS.....	6
1.2	EMC COMPATIBILITY	8
2	INTRODUCTION	9
2.1	CHECKING PACKAGE CONTENTS	9
2.2	OVERVIEW.....	10
2.3	FEATURES.....	13
2.4	ARCHITECTURE.....	13
2.5	ADDITIONAL DOCUMENTS.....	13
3	INSTALLATION.....	14
3.1	3-PH SNMP/WEB PLUG-IN ADAPTER (P/N 1024748)	14
3.1.1	Setting the logical address.....	14
3.1.2	Installing the SNMP Card in option slot.....	15
3.1.3	Connecting the card.....	16
3.2	1-PH SNMP/WEB PLUG-IN ADAPTER (P/N 1024747)	17
3.3	SP SNMP/WEB PLUG-IN ADAPTER (P/N 1024747).....	17
3.4	INTERFACES.....	18
3.4.1	UTP 10/100 – RJ45 port	18
3.4.2	RS-232 – RJ45 port.....	18
3.4.3	Contact interface – RJ11 port (1-ph plug-in version only).....	18
3.4.4	MODBUS RTU RS232.....	19
3.4.5	MODBUS RTU RS485.....	19
4	CONFIGURATION.....	20
4.1	CONFIGURATION METHODS	20
4.1.1	Configuration via serial connection.....	20
4.1.2	Configuration via the network	21
4.2	NETWORK PARAMETERS.....	22
4.2.1	Default configuration	22
4.2.2	Reboot.....	22
4.3	FURTHER INFORMATION	22
5	ACCESS.....	23
5.1	WEB INTERFACE.....	23
5.2	TROUBLESHOOTING	23
5.3	FURTHER INFORMATION	23
6	CUSTOMER SUPPORT.....	24
6.1	FIRST LINE SUPPORT	24
6.2	INTERNET.....	24
6.3	WWW SERVER.....	24
7	APPENDIX A.....	25

1 SAFETY RULES

With this document, **GE Digital Energy** gives to the user all the necessary information about the correct installation of the *SNMP/Web Adapter*.

Please read carefully this **Installation Guide** before installing or operating the adapters. We recommend that this manual be kept next to the UPS for future references.

If any problems are encountered with the procedures contained in this manual, please contact the nearest **Service Centre** before you proceed.

For more information on the **UPS** system, please refer to the applicable *Installation Guide* and *User Manual*.

All maintenance and service work should be performed by qualified service personnel only.

The **KNOWLEDGE** of (and **FULL** compliance to) the safety instructions and the warning contained in this manual are

THE ONLY CONDITION

to avoid any dangerous situations during installation, operation, maintenance work, and to preserve the maximum reliability of the UPS system.



NOTE !

While every care has been taken to ensure the completeness and accuracy of this manual, **GE Digital Energy** assumes no responsibility or liability for any losses or damages resulting from the use of the information contained in this document.

GE Digital Energy refuses any responsibility in case of non-observance, unauthorised alterations or improper use of the delivered equipment.

1.1 WARNINGS AND CAUTIONS

GENERAL

- Always strictly observe the “*UPS Safety Rules*”
- Check carefully the integrity of the equipment.
In case you note some visible damage, do not install the equipment but contact the nearest *Service Centre*.
- WARNING: RISK OF ELECTRICAL SHOCK.
Do not remove any UPS covers; there are no user serviceable parts inside.
- After switching off, it takes up to 5 minutes for the DC capacitors to discharge because a lethally high voltage remains at the terminals of the electrolytic capacitors.
- All maintenance and service work should be performed by qualified service personnel.
- The outlet-bars may be electrically live, even when the UPS is disconnected from the mains.

STORAGE

- Store the SNMP/Web adapters in a dry location; storage temperature must be within -25°C to 55°C (-13°F to 131°F).

HANDLING

- The SNMP/Web adapters are ESD sensitive devices. When handling the adapters, only touch the front panel / external cover and use suitable ESD protection (e.g. wrist straps).
- The SNMP/Web adapters contain a removable, lithium coin-cell battery.
Perchlorate Material - special handling may apply.
See www.dtsc.ca.gov/hazardouswaste/perchlorate

INSTALLATION

- Switching OFF the unit does not isolate the UPS from the mains.
- Do not install the equipment in an excessively humid environment or near water.
- Avoid spilling liquids on or dropping any foreign object onto the equipment.
- The equipment should be placed in a sufficiently ventilated area; the ambient temperature should not exceed 40°C (104°F).

BATTERY

- The SNMP/Web adapters contain a removable, lithium coin-cell battery. The battery has been selected in order to power to the relevant devices for over 10 years, therefore battery replacement should not be necessary and it is not recommended. In any case, replace only with batteries of the same type, and properly dispose or recycle used batteries.
- Never dispose of battery in a fire: they may explode.
- Do not try to open or mutilate battery: their contents may be toxic.
- Never short-circuit the battery.

ENVIRONMENT

- Please take care of packaging material: either save it for later use or recycle/dispose in compliance with local and other applicable regulations.
- The SNMP/Web adapters contain a removable, Lithium coin-cell battery. Dispose of used batteries in compliance with local and other applicable regulations.

**WARNING !**

The UPS contains hazardous voltages.

Observe carefully the safety instructions to prevent risk of electrical shock.

**CAUTION !**

The SNMP/Web adapter contains a lithium coin-cell battery.

RISK OF EXPLOSION IF BATTERY IS REPLACED BY AN INCORRECT TYPE.

DISPOSE OF USED BATTERIES ACCORDING TO THE INSTRUCTIONS.

Perchlorate Material - special handling may apply
See www.dtsc.ca.gov/hazardouswaste/perchlorate .

**CAUTION !**

The voltages on SNMP/Web Adapter are SELV rated.

Connection of high voltages to snmp/web adapter terminals will results in total damage of snmp/web adapter.

Avoid connection of high voltage to terminals.

**WARNING !**

To prevent the risk of electric shock, do not connect SELV circuits to high voltage circuits.

1.2 EMC COMPATIBILITY

1-ph SNMP/Web plug-in adapter (P/N 1024747)

This device has been tested for compliance with the following standards:

- EN 61000-6-2
- EN 61000-6-3

NOTE:

This equipment has been tested and found to comply with the limits for a Class B digital device, pursuant to Part 15 of the FCC Rules.

These limits are designed to provide reasonable protection against harmful interference in a residential installation.

This equipment generates, uses and can radiate radio frequency energy and, if not installed and used in accordance with the instructions, may cause harmful interference to radio communications.

However, there is no guarantee that interference will not occur in a particular installation.

If this equipment does cause harmful interference to radio or television reception, which can be determined by turning the equipment off and on, the user is encouraged to try to correct the interference by one or more of the following measures:

- Reorient or relocate the receiving antenna
- Increase the separation between the equipment and receiver
- Connect the equipment into an outlet on a circuit different from that to which the receiver is connected
- Consult the dealer or an experienced radio/TV technician for help

3-ph SNMP/Web plug-in adapter (P/N 1024748), 3-ph SNMP/Web plug-in adap.w/MODB.RS485 (P/N 1024921), SP-SNMP/Web plug-in adapter(P/N 1024746)

These devices have been tested for compliance with the following standards:

- EN 61000-6-2
- EN 61000-6-4

WARNING:

This is a Class A product.

In a domestic environment this product may cause radio interference in which case the user may be required to take adequate measures.

NOTE:

This equipment has been tested and found to comply with the limits for a Class A digital device, pursuant to Part 15 of the FCC Rules.

These limits are designed to provide reasonable protection against harmful interference when the equipment is operated in a commercial environment.

This equipment generates, uses, and can radiate radio frequency energy and, if not installed and used in accordance with the instruction manual, may cause harmful interference to radio communications. Operation of this equipment in a residential area is likely to cause harmful interference in which case the user will be required to correct the interference at his own expense.

2 INTRODUCTION

2.1 CHECKING PACKAGE CONTENTS

The SNMP/Web adapters are delivered in different kits according to the model.

3-ph SNMP/Web plug-in adapter (P/N 1024748)/ 3-ph SNMP/Web plug-in adap.w/MODB.RS485 (P/N 1024921)

- 3-ph SNMP/Web plug-in adapter, with pre-installed standard front panel
- A front panel designed for LP33 Series UPSs
- Square plates for older SitePro UPSs
- Mounting screws
- Installation Guide
- Third Party License ReadMe
- CD-ROM
- RJ45- DB9 connectivity console cable

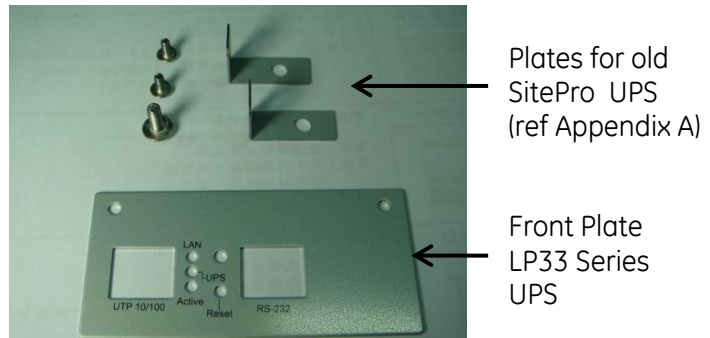

1-ph SNMP/Web plug-in adapter (P/N 1024747)

- 1-ph SNMP/Web plug-in adapter
- Installation Guide
- Third Party License ReadMe
- CD-ROM
- RJ45- DB9 connectivity console cable

SP SNMP/Web plug-in adapter (P/N 1024746)

- SP SNMP/Web plug-in adapter
- Installation Guide
- Third Party License ReadMe
- CD-ROM
- RJ45- DB9 connectivity console cable

2.2 OVERVIEW

3-ph SNMP/Web plug-in adapter (P/N 1024748),

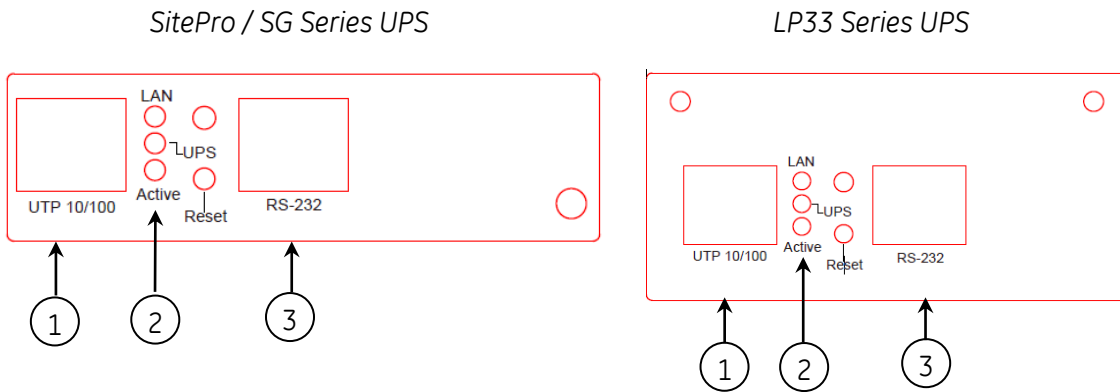

- 1 – RJ45 Connector Ethernet connection, 10Base-T or 100Base-TX
- 2 – LEDs Ref. specific section
- 3 – RS-232 port Local console connection (115200-N-8-1)

3-ph SNMP/Web plug-in adap.w /MODB.RS485 (P/N 1024921)

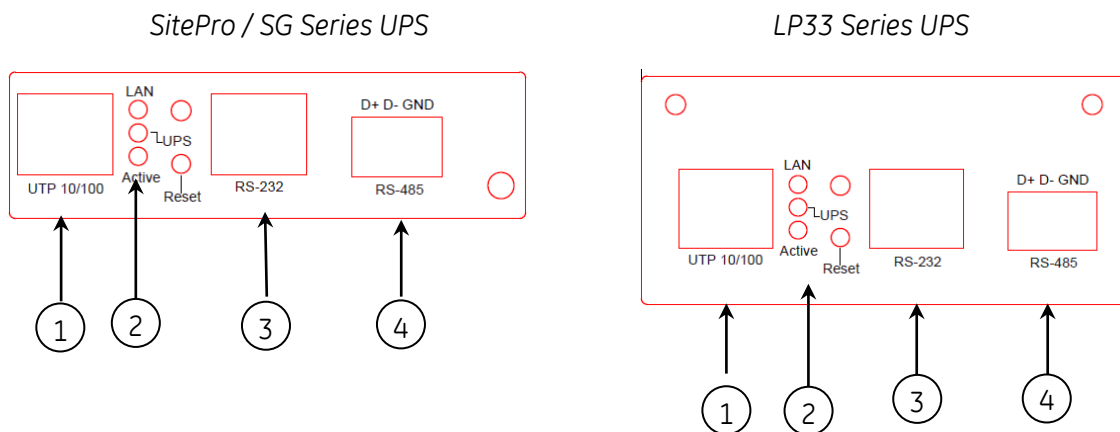

- 1 – RJ45 Connector Ethernet connection, 10Base-T or 100Base-TX
- 2 – LEDs Ref. specific section
- 3 – RS-232 port Local console connection (115200-N-8-1)
- 4 – RS485 Port MODBUS RS485 Port

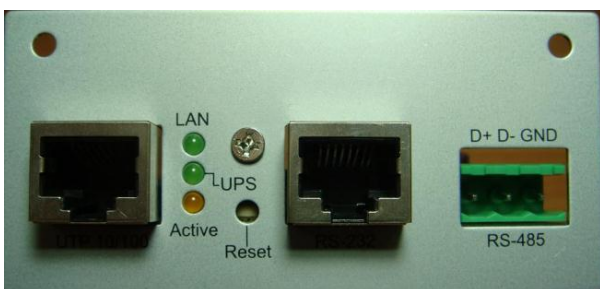

Front Panel view of 3-ph SNMP/Web plug-in adap.w/ MODB.RS485 (P/N1024921)

RS485 port following are connection details:

Pin1----- D+

Pin2----- D-

Pin3----- GND

Wire Size –12~24 AWG

Tightening Torque –7.0 lb-in

1-ph SNMP/Web plug-in adapter (P/N 1024747)

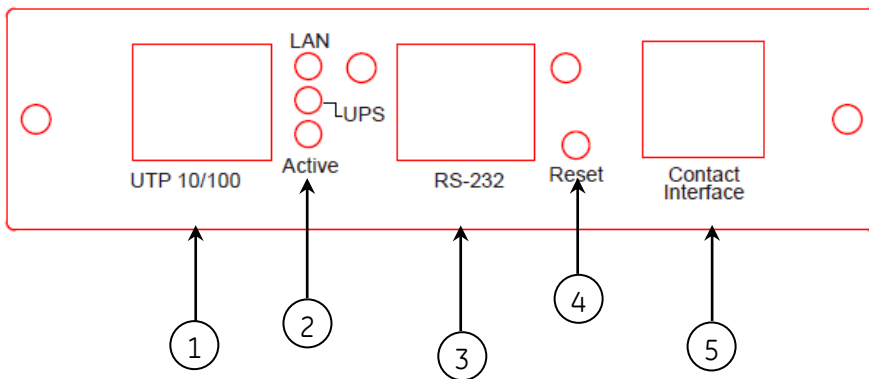

Front panel –
User interface view

- 1 – RJ45 Connector Ethernet connection, 10Base-T or 100Base-TX
- 2 – LEDs Ref. specific section
- 3 – RS-232 port Local console connection (115200-N-8-1)
- 4 – Reset button HW reset
- 5 – RJ11 Connector Contact interface, open-collector output

SP SNMP/Web plug-in adapter (P/N 1024746)

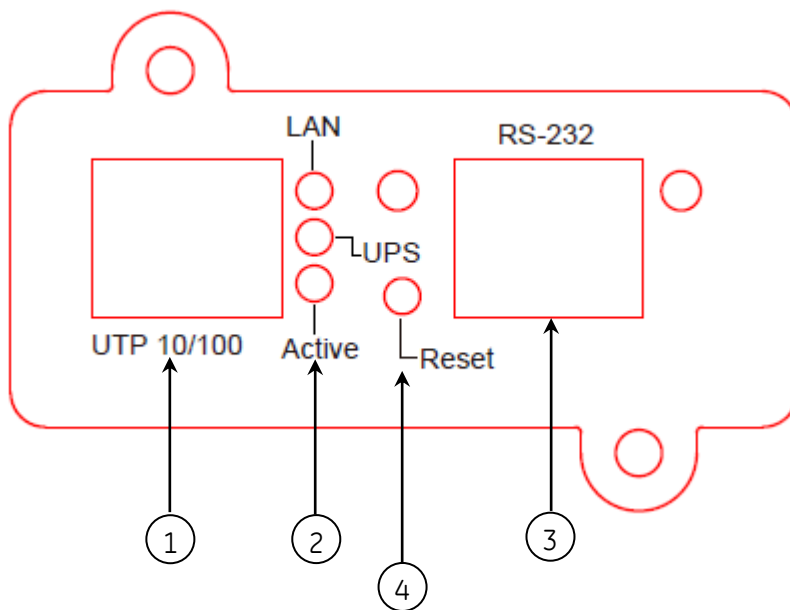

- 1 – RJ45 Connector Ethernet connection, 10Base-T or 100Base-TX
- 2 – LEDs Ref. specific section
- 3 – RJ45 Connector RS-232 - Local console connections (115200-N-8-1)
- 4- Reset button HW reset

LEDs

The various front panel LEDs have the following meaning:

- LAN / Netlink

Status	Meaning
<i>Off</i>	No LAN connection detected
<i>On</i>	LAN connection established, no communication
<i>Blink</i>	LAN connection established, receive or transmit active

- UPS / Fail

Status	Meaning
<i>Off</i>	OK / No Fault
<i>On</i>	No UPS Connection

- Active

Status	Meaning
<i>Off</i>	Fault of device
<i>Blink</i>	Device OK / No fault

Jumper Selection

Following are the factory default jumper selection for SNMP/Web Adapters. To activate Modbus RTU RS232 protocol a change in the default selection is required. Please refer the Modbus RTU RS232 section for jumper selection details.

Product Part Description	Jumper Position
1024746 -SP SNMP Web/ Adapter	J3 : 1-2 ; J4 : 1-2
1024747 -1 Ph SNMP Web /Adapter	J4 : 1-2 ; J5 : 1-2
1024748 -3 ph SNMP Web Adapter	J3 : 1-2 ; J4 : 1-2
1024921 -3 ph SNMP w.MODB.RS485	J3 : 1-2 ; J4 : 1-2

Factory default jumper configuration is necessary for SNMP /Web Adapter installation and commissioning please ensure the default configuration as per the above table and it is advised **not to change the jumper selection.**

2.3 FEATURES

Each SNMP/Web adapter provides the following features:

- 10/100 Mbps connection speed
- Use of DHCP / BOOTP or manual configuration for the TCP/IP network settings
- SNMP Agent
- Web server
- Console interface
- UPS status / alarms / readings, event logging over different interfaces
- Digital outputs (open-collector outputs for relay drive) – *1-ph plug-in version only*
- SNMP Traps and E-mail notification upon UPS event
- Advanced security features

2.4 ARCHITECTURE

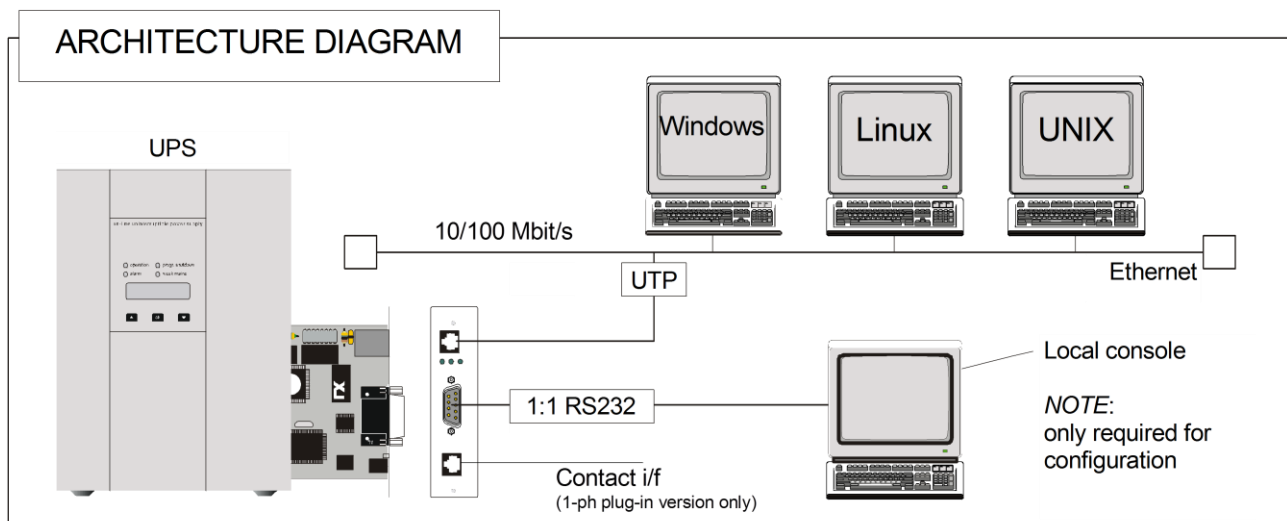

2.5 ADDITIONAL DOCUMENTS

The SNMP/Web adapter is provided with a CD-ROM containing the following documentation:

- Installation Guide
- User Manual
- SNMP Management Information Base (MIB)
- Release notes and other instructions, as applicable

3 INSTALLATION



NOTE !

Strictly observe the '*UPS Safety Rules*'.

Read carefully the UPS '*User Manual & Installation Guide*' before installing or operating the equipment.

If any problems are encountered with the installation procedure here described, please contact the nearest *Service Centre* before proceeding.

3.1 3-ph SNMP/WEB plug-in adapter (P/N 1024748)



NOTE ! SitePro customers only

SitePro units produced before 2003 require an additional protective ground connection – refer to APPENDIX A.

3.1.1 Setting the logical address

The logical address is configured through dip-switch SW1 in the following way:

	Logical Address	Dip 1	Dip 2
SNMP Card 0 ⁽¹⁾	54	ON	ON
SNMP Card 1	55	ON	OFF
SNMP Card 2	56	OFF	ON
SNMP Card 3	57	OFF	OFF

(1) Default setup

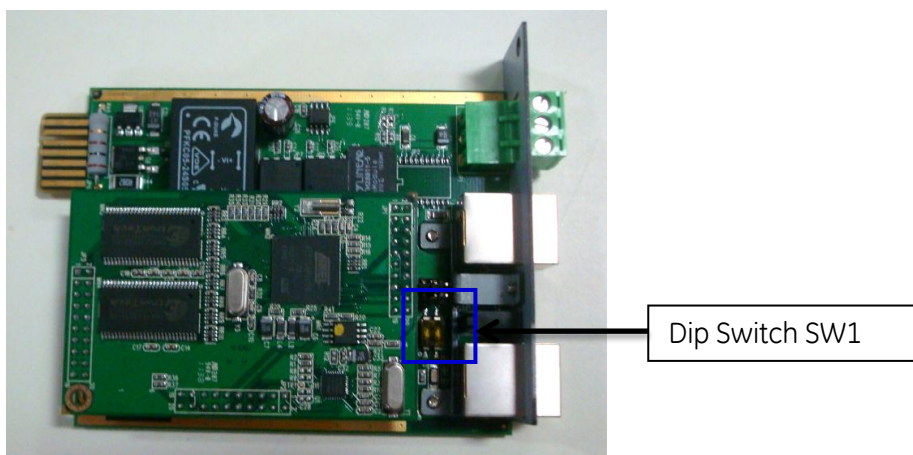

NOTE: The logical address is a critical setting when more than one *SNMP Card* is installed in the same UPS system.

3.1.2 Installing the SNMP Card in option slot

IMPORTANT: Switch off the UPS, and wait approx. 2 minutes or switch the UPS to the manual bypass. In the latter case, please ensure that the mains input is reliable during this period. All cables must be disconnected from the card during the installation.

Install procedure for LANPRO 33 / LP33 Series

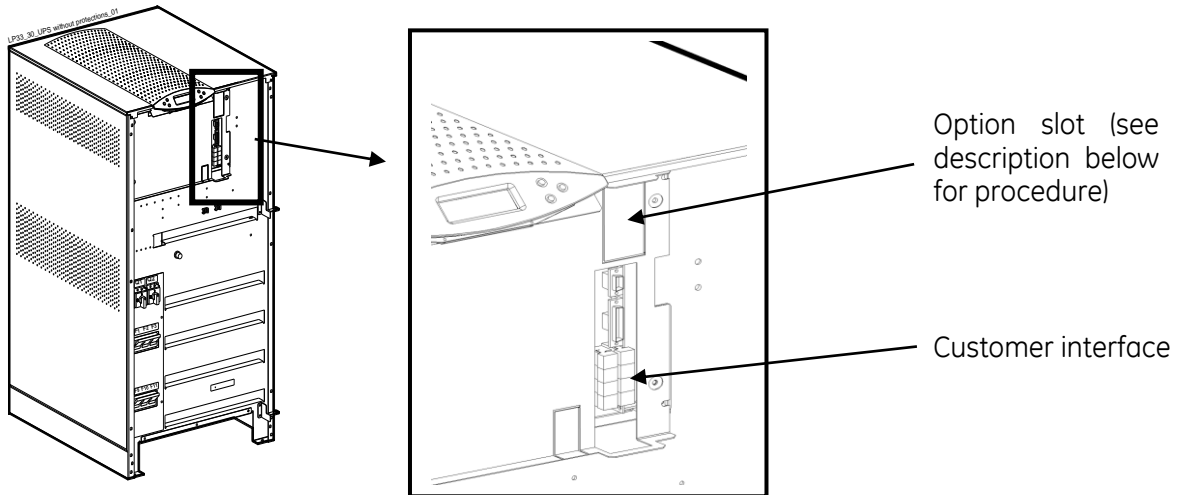

1. Remove the plate that covers the Option slot by cutting the edges which are holding the plate. **Take care the plate does not fall inside the UPS!**
2. Slide carefully the *SNMP adapter* into the Options slot.
3. Fix the front plate of the *SNMP adapter* to the UPS, using the screw included in the *SNMP/Web adapter kit*.

Install procedure for SitePro S6

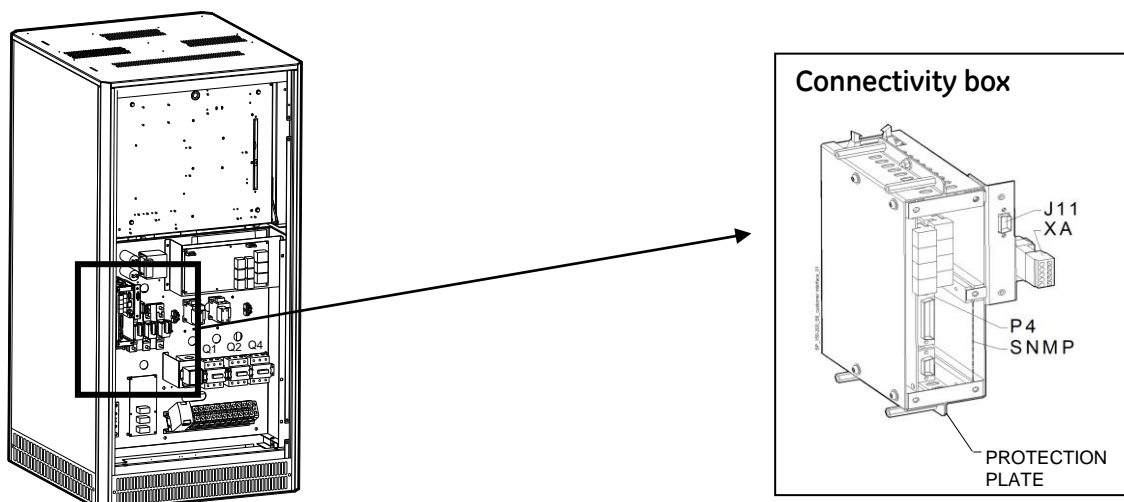

1. Change the front plate with the smaller one delivered with the Kit.
2. Insert the *SNMP adapter* in the options slot.
3. Fix the front plate of the *SNMP adapter* to the connectivity box, using the screw included in the *SNMP/Web adapter kit*.

Install procedure for SG Series

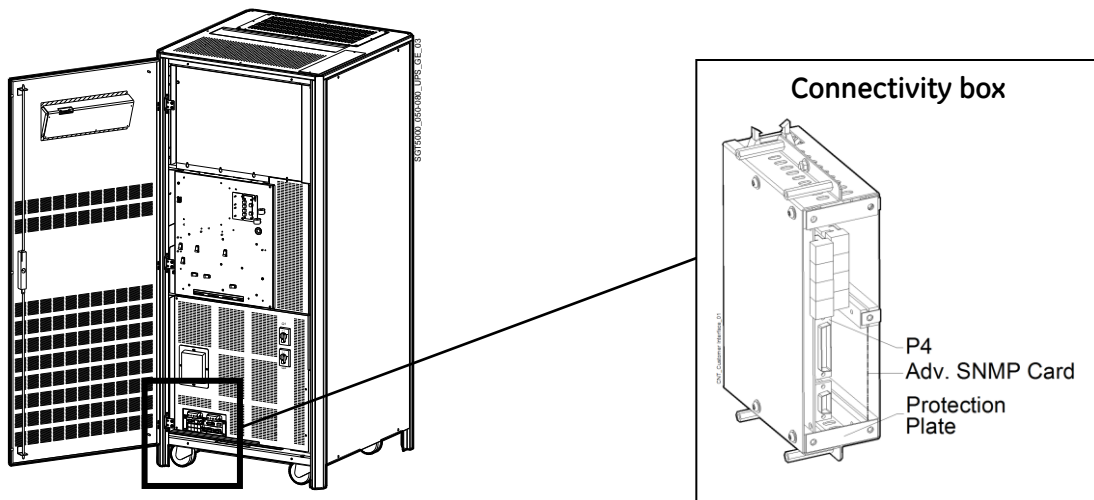

1. Change the front plate with the smaller one delivered with the Kit.
2. Insert the *SNMP adapter* in the options slot.
3. Fix the front plate of the *SNMP adapter* to the connectivity box, using the screw included in the *SNMP/Web adapter kit*.

3.1.3 Connecting the card

Refer to the architecture detailed in *Section 2.4*.

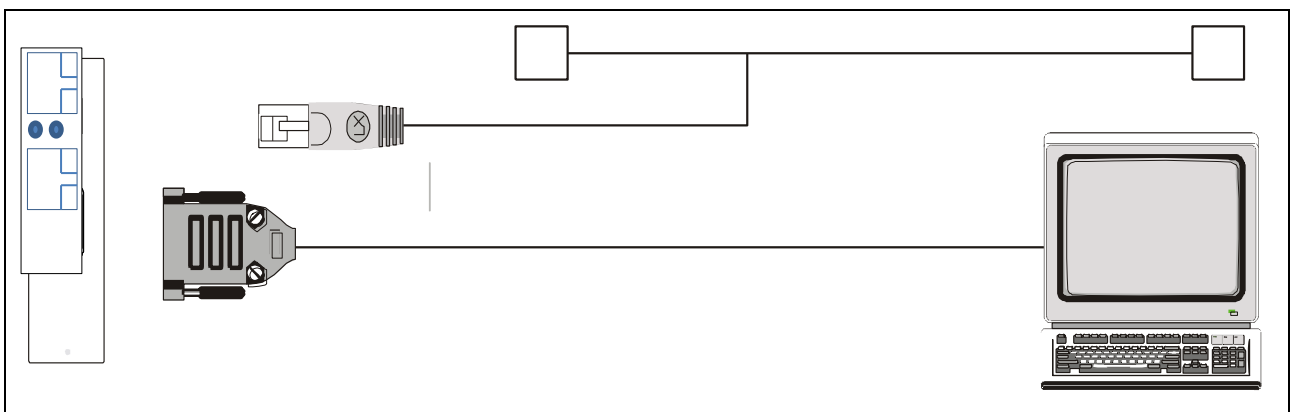

Now, the UPS may be switched on (or back to normal mode from manual bypass).

3.2 1-ph SNMP/WEB plug-in adapter (P/N 1024747)

- Switch off the UPS, and wait approx. 2 minutes or switch the UPS to the manual bypass. In the latter case, please ensure that the mains input is reliable during this period.
- Install the SNMP/WEB Interface card in the RS232 option slot. For more details about the slot please read the UPS User Manual.

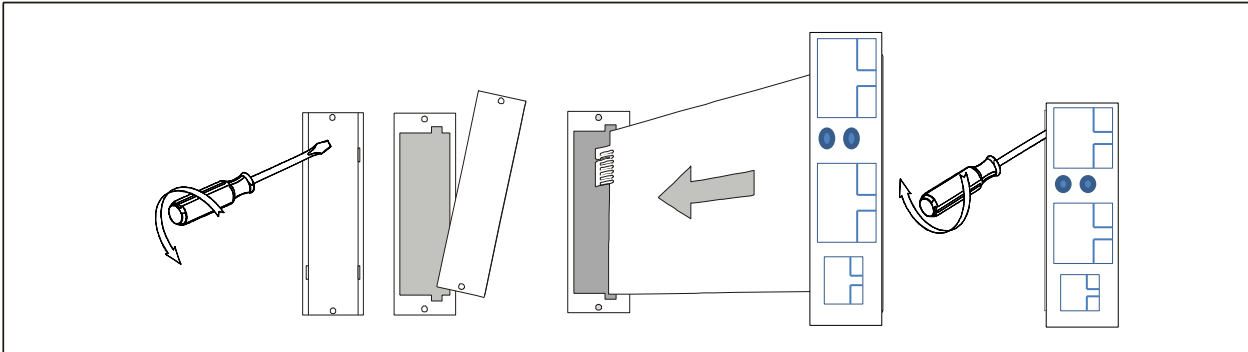

- Make all necessary connections (see architecture diagram in section 2.4).

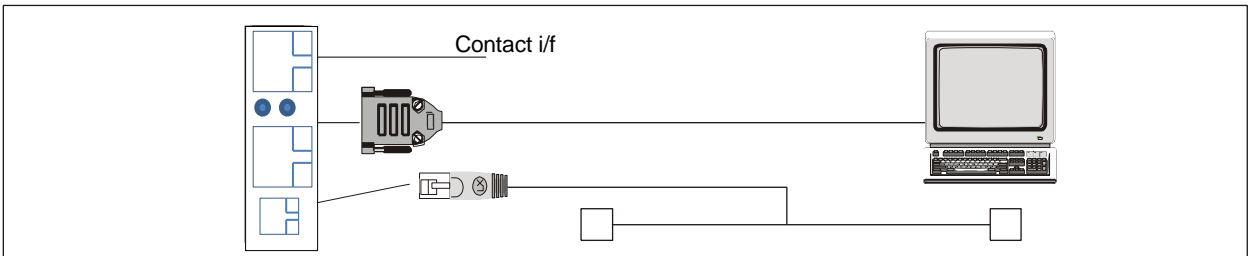

- Switch on the UPS or go back to normal mode from bypass.

3.3 SP SNMP/WEB plug-in adapter (P/N 1024747)

- Switch off the UPS, and wait approx. 2 minutes or switch the UPS to the manual bypass. In the latter case, please ensure that the mains input is reliable during this period.
- Install the SNMP/WEB Interface card in the RS232 option slot. For more details about the slot please read the UPS User Manual.

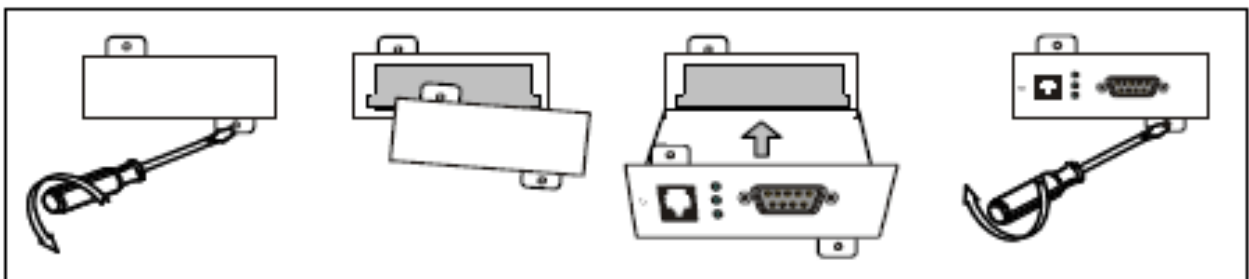

- Make all necessary connections (see architecture diagram in section 2.4).

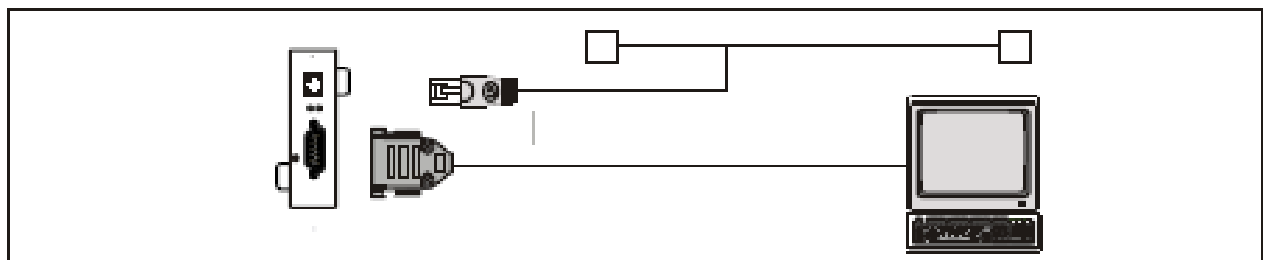

- Switch on the UPS or go back to normal mode from bypass.

3.4 INTERFACES

3.4.1 UTP 10/100 – RJ45 port

Connection to Ethernet 10/100 Mbits/s networks, using a UTP cable.

3.4.2 RS-232 – RJ45 port

Serial communication, connection to a local console.

Use the serial cable provided with snmp/web adapter (RJ45 to DB9) for connection to a PC.

Connector pin-out as follows:

Pin #	Function
5	TD – Transmit Data
6	RD – Receive Data
4	GND

3.4.3 Contact interface – RJ11 port (1-ph plug-in version only)

Plug-in contact interface port.

Connector pin-out as follows:

Pin #	Function	Pin #	Function
1	Mains failure	4	On bypass / AVR**
2	General alarm *	5	N.C.
3	Battery low	6	GND

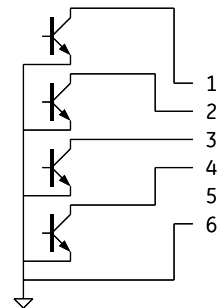

(*) Active if the output voltage of the UPS is no longer guaranteed due to other circumstances than already indicated by pin 1-3-4.

(**) AVR (Automatic Voltage Regulation) function on line-interactive UPS only (e.g. Match Series)

Contact interface outputs are specified for the following ratings:

- I_C max, closed 30mA
- V_{CE} max, closed 0,4V [@1mA]
- V_{CE} max, open 48V



CAUTION !

The RJ45 and RJ11 port share the same GND signal.

Exercise caution when both interfaces are used at the same time, particularly when connecting these interfaces to non-floating ground systems.

3.4.4 MODBUS RTU RS232

Modbus RTU RS232 protocol is available with console connection RJ45 port. The RJ45 to DB9 cable shall connect the Modbus RTU slave of SNMP /Web adapter to the PC running the Modbus Master program.

Follow the below instructions to activate and make Modbus RTU RS232 operational:

- After entering the required license key the Modbus Protocol is activated. Please refer to the user manual for necessary commands to activate the Modbus Protocol
- After the license is activated Plug out the SNMP card from UPS
- Based on SNMP /Web Adapter model, select the jumpers as per the table below for Modbus RTUS RS232 to operate

Product Part Description	Jumper Position
1024746 -SP SNMP Web/ Adapter	J3 : 2-3 ; J4 : 2-3
1024747 -1 Ph SNMP Web /Adapter	J4 : 2-3 ; J5 : 2-3
1024748 -3 ph SNMP Web Adapter	J3 : 2-3 ; J4 : 2-3
1024921 -3 ph SNMP w.MODB.RS485	J3 : 2-3 ; J4 : 2-3

- Plug-in the card back into the UPS
- Connect the RJ45 –DB9 cable RJ45 end to the RJ45(RS232) port of SNMP card, connect the DB9 end of this cable to the PC running the modbus master program
- Start the Modbus master program(for eg: Modbus tool) and start the communication with the respective settings done for SNMP card
- Please note console interface and is disabled when Modbus RS232 is active and functioning, to reactivate the console connection restore the jumpers to the standard position and console will be operational

3.4.5 MODBUS RTU RS485

Modbus RTU RS485 is available with part number 1024921.Modbus RS485 is available at the RS-485 port.

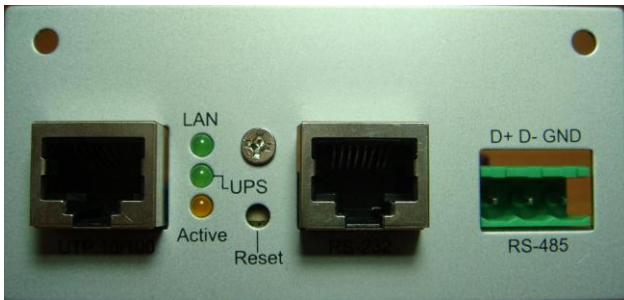

Front Panel view of 3-ph SNMP/Web plug-in adap.w/ MODB.RS485 (P/N1024921)

- RS485 port following are connection details:
 - Pin1----- D+
 - Pin2----- D-
 - Pin3----- GND
- Wire Size –12~24 AWG
- Tightening Torque –7.0 lb-in

A three pin phoenix connector is provided for Modbus RS485 connections.

Follow the below instructions to activate and make Modbus RTU RS232 operational:

- After entering the required license key the Modbus RS485 protocol is activated. Please refer to the user manual for necessary commands to activate the Modbus RS485 protocol
- Perform the connections as per the below details
 - Pin1----- D+
 - Pin2----- D-
 - Pin3----- GND
 - Wire Size – 12~24 AWG
 - Tightening Torque -7.0 lb-in
- The Modbus RS485 protocol is available now and can be accessed through the above mentioned connections and can be accessed as per the user criteria

4 CONFIGURATION

4.1 CONFIGURATION METHODS

The SNMP/Web plug-in adapters can be configured using different interfaces.

4.1.1 Configuration via serial connection

- Connect the SNMP adapter to a computer using the RJ45-DB9 serial cable provided with the kit
- Run a terminal simulator (e.g. *HyperTerminal* on a PC running Windows)
- Configure the terminal simulator as follows:
115,200bps, 8 data bits, 1 stop bit, parity none, flow control none
Terminal emulation VT-100

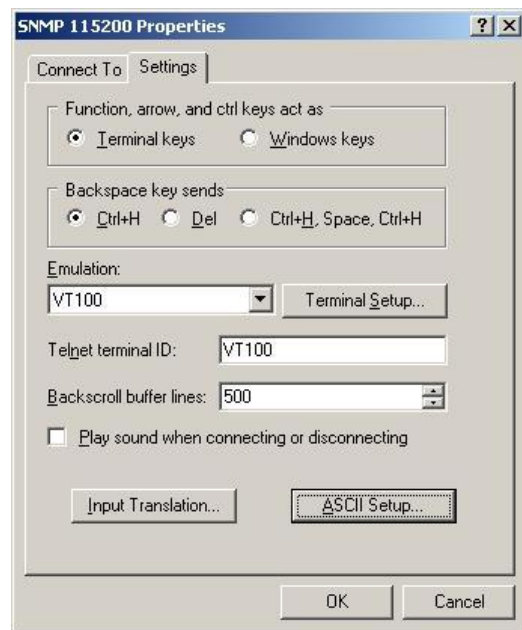
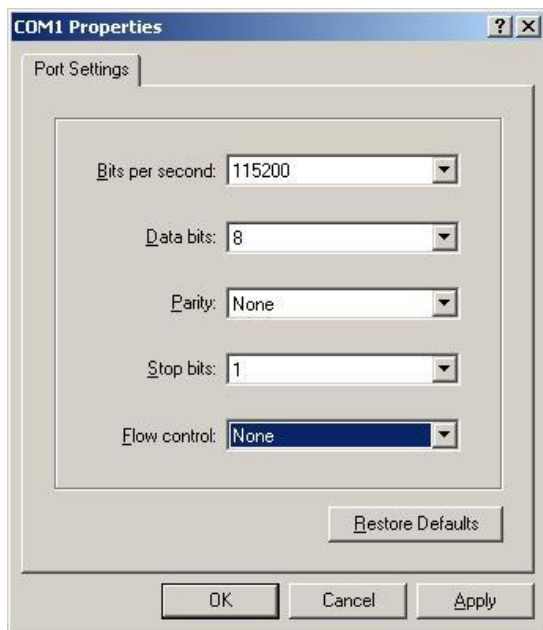

- Establish the connection and press **<enter>**
- The default username (login) and password are *ge* and *ge*
- A command-line configuration interface is entered. Type *menu* to enter the quick network configuration menu:

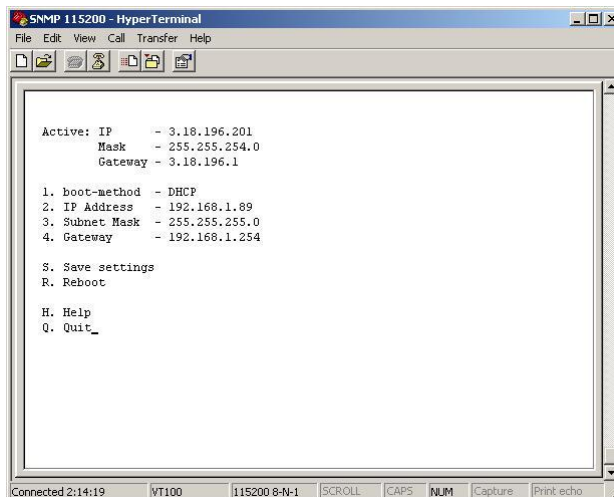

NOTE:

Although the console interface provides a full set of commands, access using the serial connection is only needed for initial configuration when no DHCP server is available, or the IP-address is unknown. The quick network configuration menu provides a simple interface for basic network configuration. For all other settings the user-friendly web interface is recommended.

NOTE: Save the settings!

Apart from some network parameters, most settings are immediately active. However, the adapter will revert to the last saved settings at reboot.

Therefore, in order to permanently modify the SNMP/Web adapter setting, remember to save the configuration after every change.

This can be done:

- Pressing **S** on the quick configuration menu
- Entering *nvsave* at the command interface prompt

4.1.2 Configuration via the network

TELNET

- Launch a telnet client (e.g. on a PC running Windows, select *Run* from the *Start* menu and type **telnet <IP>**)
- The default username (login) and password are *ge* and *ge*
- A command-line configuration interface is entered

WEB BROWSER

- Launch a web browser
- Enter the URL of the SNMP/Web adapter: **http://<IP>/**
- The default username and password are *ge* and *ge*
- Navigate the pages using the menu bar

NOTE: Save the settings!

Apart from some network parameters, most settings are immediately active.

However, the adapter will revert to the last saved settings at reboot.

Therefore, in order to permanently modify the SNMP/Web adapter setting, remember to save the configuration after every change.

4.2 NETWORK PARAMETERS

The SNMP/Web adapter connects to the network using the following parameters:

- **IP address** identifies the adapter on the network.
- **Subnet mask** defines a range of addresses within the organisation.
- **Gateway** the node used for connection to addresses outside the subnet.

The adapter can be configured to obtain these settings automatically using DHCP or BOOTP protocols, or to use static addresses (manual configuration).

4.2.1 Default configuration

The SNMP/Web adapter comes with a pre-configured **MAC address**, with the following format:

00:12:93:Fx:xx:xx 00:12:93 identifies the manufacturer.
 x:xx:xx is a unique code for every adapter.

The MAC address is written on a label sticker on the SNMP/Web adapter.

The factory default configuration for the SNMP/Web adapter is using DHCP. Assign the IP address to the adapter MAC address in your DHCP server.

Then reboot the adapter in order to have it retrieve the IP address. The adapter is now accessible and configurable over the network.

4.2.2 Reboot

Every time the network settings are changed, these become effective only after a reboot. The adapter can be rebooted:

- Manually, pressing the reset button on the front of the adapter
- Using the console interface (either serial connection or telnet) by injecting the **reboot** command
- Using a web browser, selecting '**Reboot**' in the menu

4.3 Further information

For more information, and in order to make full use of all advanced functionalities provided by the SNMP/Web adapter, refer to the *User Manual* available on the CD-ROM

5 ACCESS

5.1 WEB INTERFACE

After the installation and configuration of the SNMP/Web adapter, the connection can be tested with a web browser.

- Launch the browser
- Enter the URL of the SNMP/Web adapter: **http://<IP>/** (e.g. http://192.168.24.14/)
- When prompted, enter username and password (by default, these are set to *ge* and *ge*)
- The SNMP/Web adapter home page will be shown

5.2 TROUBLESHOOTING

If no answer is received from the adapter, verify the adapter installation, cabling and network configuration.

Check the Ethernet connection to the adapter by launching a *ping* command from a workstation in the same subnet.

E.g. in a Windows system:

- Select *Run* from the *Start* menu
- Enter **ping <IP>** (e.g. ping 192.168.24.14)
- Verify that the SNMP Card adapter is correctly replying

5.3 FURTHER INFORMATION

For more information, and in order to make full use of all advanced functionalities provided by the SNMP/Web adapter, refer to the *User Manual* available on the CD-ROM

6 CUSTOMER SUPPORT

6.1 FIRST LINE SUPPORT

Please contact your local GE distributor for problems with the installation of the product or its use.

6.2 INTERNET

On-line support available on request (Internet access required).

6.3 WWW SERVER

We have a WWW server running at

www.gedigitalenergy.com

With your favourite web browser you can access the latest information from GE, and download updates and manuals for this product.

7 APPENDIX A

SitePro EARTH CONNECTION

In order to guarantee correct functional behaviour, the SNMP/Web plug-in adapter must be connected to protective earth (UPS chassis).

On SitePro UPSs manufactured before 2003 the square plates (delivered with the 3-ph adapter kit) must be mounted – refer to the pictures below for the installation details.

Note: Should the UPS be already equipped with the plates, please ignore this step.

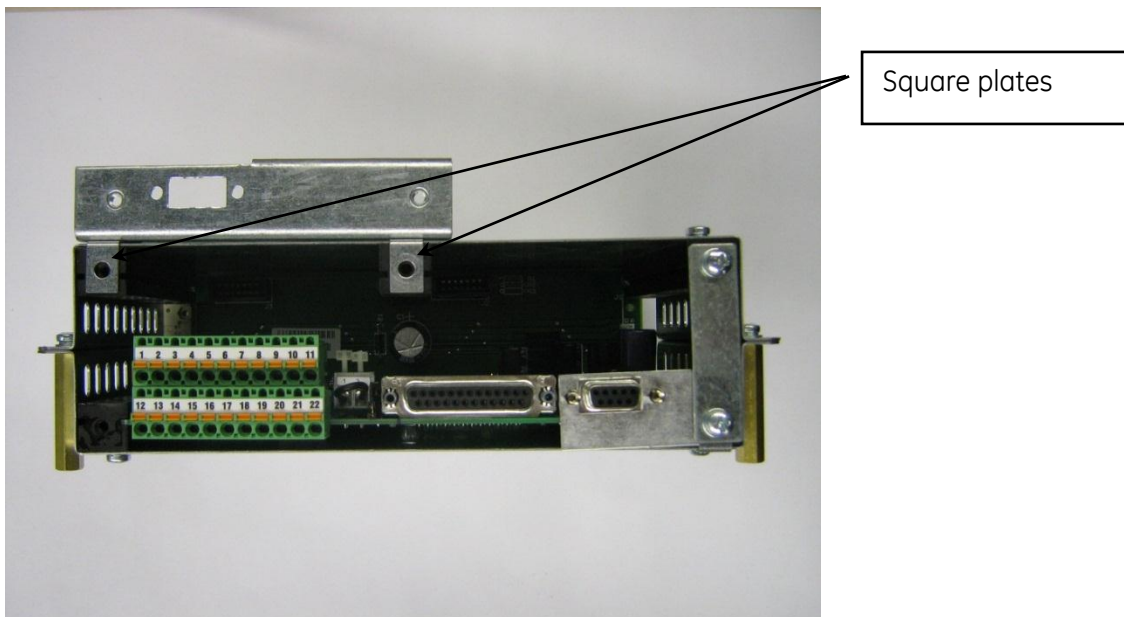

Square plates mounting position

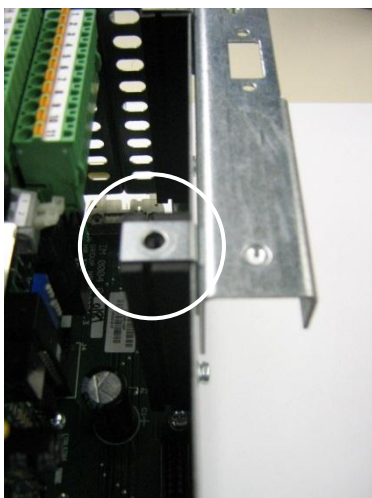

Square plate mounting – detail

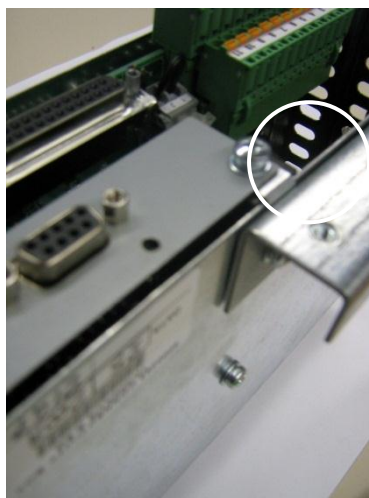

Plug-in adapter earth connection