



LD50 Luminescence Sensor

INSTRUCTION MANUAL

CONTROLS

OUTPUT LED (yellow)
The yellow LED indicates the output status.

READY LED (green)
During functioning, the green LED permanently ON indicates a normal operating condition; fast blinking indicates an output overload condition.

SENSITIVITY LED (orange)
The orange LED ON indicates that the maximum sensitivity has been set. LED blinking signals the sensitivity adjustment mode.

UP / DOWN PUSH-BUTTON
The sensitivity setting procedure is activated by pressing the UP and DOWN push-buttons



See the "SETTING" paragraph for setup procedure indications.

INSTALLATION

The sensor can be positioned using threaded M5 holes with 6mm max. depth.
Do not apply excessive torque when adjusting (max 2.2 Nm).

The operating distance is measured starting from the lens front face.

CONNECTIONS

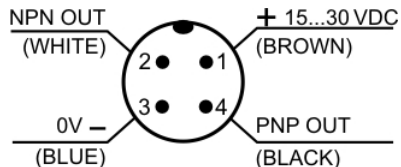

DIMENSIONS

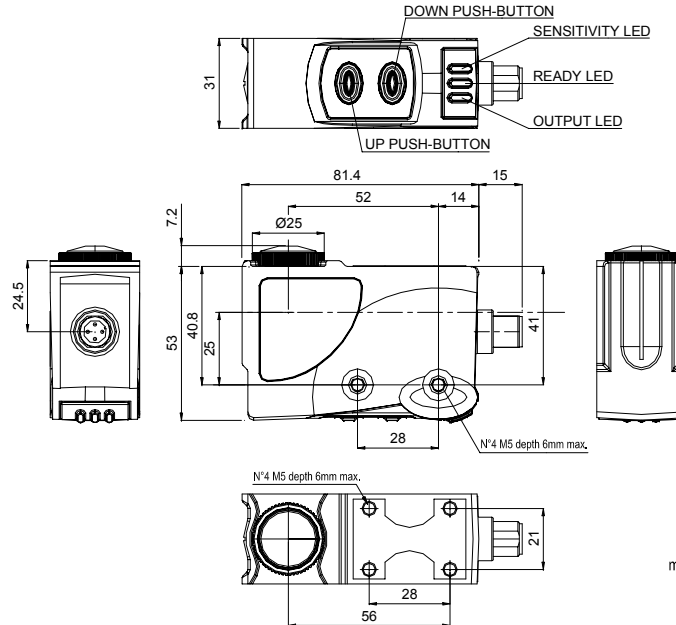

TECHNICAL DATA

Power supply:	15...30 Vdc limit values
Ripple:	2 Vpp max.
Current consumption (output current excluded):	50 mA max @ 24Vdc
Output:	1 PNP output / 1 NPN output
Output current:	100 mA max.
Output saturation voltage:	≤ 2 V
Response time:	250 μs
Switching frequency:	2 kHz
Indicators:	OUT LED (yellow) / READY LED (green) SENSITIVITY LED (orange)
Push-button:	UP / DOWN
Sensitivity:	selectable (default configuration maximum)
Operating temperature:	-10 ... 55 °C
Storage temperature:	-20 ... 70 °C
Insulating strength:	500 Vac 1 min., between electronics and housing
Insulating resistance:	>20 MΩ 500 Vdc, between electronics and housing
Operating distance:	10...20 mm
Minimum spot dimension:	2x7mm @ 10mm
Emission type:	LEDs UV 375nm
Ambient light rejection:	According to EN 60947-5-2
Vibrations:	0.5 mm amplitude, 10 ... 55 Hz frequency, for each axis (EN60068-2-6)
Shock resistance:	11 ms (30 G) 6 shock for each axis (EN60068-2-27)
Housing material:	ABS
Lens material:	glass
Mechanical protection:	IP67
Connections:	M12 4-pole connector
Weight:	90 g. max.

SETTING

SENSITIVITY

The sensor reading sensitivity, i.e. the ability to detect luminescent objects is adjusted in this mode. Press UP to increase sensitivity (for detection of marks with a lower luminescent degree), press DOWN to decrease sensitivity. Keep both push-buttons pressed to increase the sensitivity increase/decrease speed. The orange SENSITIVITY LED blinks with a frequency proportional to the sensitivity set. The orange LED lit ON indicates that the maximum sensitivity has been set.



The sensitivity value is automatically saved after 30sec from last setting.



MAXIMUM SENSITIVITY SETTING

To set the maximum sensitivity, press contemporaneously the UP or DOWN push-buttons for 2 sec until the orange SENSITIVITY LED turns ON.



OUTPUT OVERLOAD

The digital output overload is signalled by the fast blinking of the READY LED.

	EX-II-3-D T6	
	Temperature class:	T6 (<85°C)
	Max. Power consumption:	1500 mW at 30 Vdc
	Max. Internal capacitance:	750 nF
	Internal inductance:	negligible

DECLARATION OF CONFORMITY

We DATASENSOR S.p.A. declare under our sole responsibility that these products are conform to the 2004/108/CE, 2006/95/CE Directives and successive amendments.



WARRANTY

DATASENSOR S.p.A. warrants its products to be free from defects. DATASENSOR S.p.A. will repair or replace, free of charge, any product found to be defective during the warranty period of 36 months from the manufacturing date. This warranty does not cover damage or liability deriving from the improper application of DATASENSOR products.

DATASENSOR S.p.A. Via Lavino 265
40050 Monte S. Pietro - Bologna - Italy
Tel: +39 051 6765611 Fax: +39 051 6759324
<http://www.datasensor.com> e-mail: info@datasensor.com



DATASENSOR S.p.A. cares for the environment: 100% recycled paper. DATASENSOR S.p.A. reserves the right to make modifications and improvements without prior notification.