



## S65-PA-5-Z

Line sensor

### INSTRUCTION MANUAL

#### CONTROLS

##### OUTPUT LED

The yellow LED ON indicates the active output status.

##### DISPLAY (green-coloured 4 digit display)

The display indicates the value of the measurement detected in function of the operating mode function

Please refer to the 'SETTING' paragraph for the correct indications to follow during the acquisition or setting phase.

##### M1, M2 LEDs

The LED couple visualises the operating mode according to the table given below:

OPERATING MODE	M1 LED	M2 LED
Object TOP – Object BOTTOM	OFF	OFF
Object centre position	OFF	ON
Width measurement	ON	OFF
Area	ON	ON

##### ALLARM LED

The blinking of the alarm LED indicates that the received signal is insufficient for correct sensor functioning. In this case, the "digital alarm" output is activated.

##### +/- AND SET PUSHBUTTONS

Please refer to the following paragraphs for the correct indications to follow during the parameter setting phase

#### TECHNICAL DATA

Power supply:	10 ... 30 Vdc limit values
Ripple:	2 Vpp max.
Consumption (output current excluded):	70 mA max.
Outputs:	1 PNP or NPN output 30 Vdc max. (short circuit protection) 1 PNP or NPN alarm output 30 Vdc max. (short circuit protection) 4-20mA analogue output
Serial interface:	RS485, 9600B, 8, N, 1
SYNC input:	PNP
Output current:	100 mA max.
Output saturation voltage:	≤ 2 V
Switching frequency:	> 130 Hz
Indicators:	4 digit display (GREEN), OUTPUT LED (YELLOW) 1 ALARM LED (GREEN) 2 LEDs (M1, M2) operating mode (GREEN)
Setting:	+, -, SET push-buttons
Data retention:	non volatile EEPROM memory
Operating temperature:	-10 ... 55 °C
Storage temperature:	-20 ... 70 °C
Electrical protection:	Class 2
Operating distance (typical values):	200 mm
Measurement range:	150 mm
Minimum object detectable:	0.9 mm
Resolution:	0.15 mm
Linearity:	1% max.
Emission type:	infrared (875nm)
Ambient light rejection:	according to EN 60947-5-2
Vibrations:	0.5 mm amplitude, 10 ... 55 Hz frequency, for each axis (EN60068-2-6)
Shock resistance:	11 ms (30 G) 6 shock for each axis (EN60068-2-27)
Housing material:	ABS
Lens material:	Glass window and lenses
Mechanical protection:	IP67
Connections:	8-pole M12 connector
Weight:	100 g. max.

#### DIMENSIONS

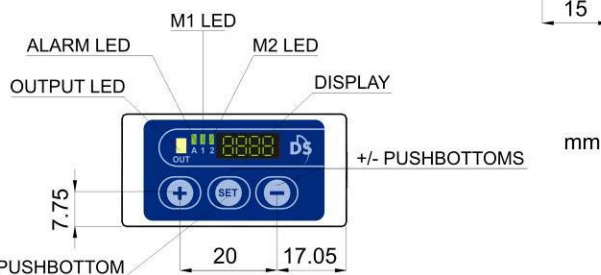
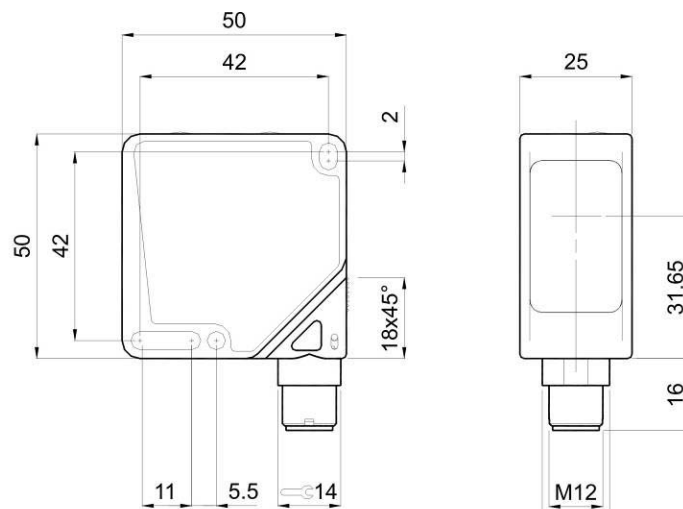

#### INSTALLATION

The sensor can be mounted by means of the three housing's holes using two screws (M4x25 or longer, 1 Nm maximum tightening torque) with washers. The use of fixing brackets is recommended if the supporting surface doesn't have a good planarity. Various orientable fixing brackets to ease the sensor positioning are available (please refer to the accessories listed in the catalogue). The operating distance is measured from the front surface of the sensor optics.

The M12 connector can be oriented at three different positions using the specific fastening spring and rotating the block of 180°.

#### CONNECTION

##### M12 CONNECTOR

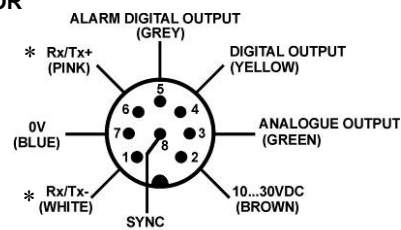

\* Available only for the versions with RS485 serial interface (S65-PA-5-Z09-xxxZ).

**NOTE: The wire colours are referred to the cables manufactured according to the European standard.**

#### FUNCTIONING

The S65-PA-5-Z sensor is a line sensor. The reflective tape (inside the package) has to be positioned in front of the sensor. The sensor illuminates the tape and receives back the reflected light. Any object positioned between the tape and the sensor is detected.

The sensor has 5 operating modes:

- **Object TOP:** the position of the top edge is detected.
- **Object BOTTOM:** the position of the bottom edge is detected.
- **Object centre:** the centre of the object is measured.
- **Width:** the width object is measured (Distance between the first one and the second edge).
- **Area:** areas obscured by one or more objects are measured.

According to the set operating mode, the sensor effects a measurement, visualises it on the display and supplies on the analogue output a voltage proportional to this measurement.

The measurement values according to set operating modes and object positions inside the detection area are indicated below.

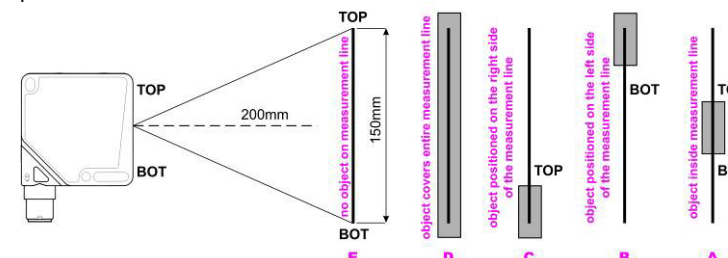

	TOP position	BOTTOM position	Centre position	Width	Area
<b>A</b>	Top	Bot	(Top+Bot)/2+Bot	Bot-Top	Bot-Top
<b>B</b>	Bot	Bot	0	0	Bot
<b>C</b>	Top	Top	0	0	1023-Top
<b>D</b>	0	0	0	0	1023
<b>E</b>	0	0	0	0	0

Do not illuminate the reflective tape with direct light in order to avoid jeopardising the correct sensor functioning.

#### APPLICATION NOTES

The drawing given below shows how the same object can generate different obscured zones if placed in different positions or different distances inside the sensor operating area.

The "Area" operating mode is particularly sensitive to the reflecting tape's characteristics and for this reason the sensor can detect the main specifications of the tape used.

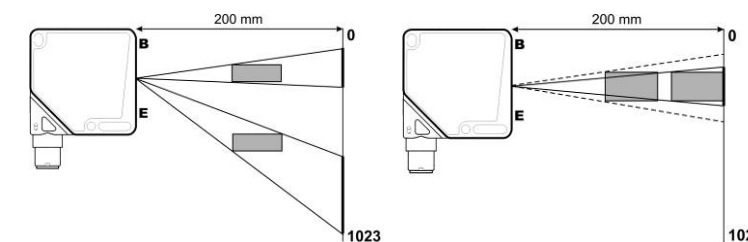

#### PRELIMINARY OPERATIONS

The following preliminary operations are recommended to obtain best sensor functioning.

##### - Operating area selection

This operation eliminates insignificant areas inside the sensor operating area, as for example in presence of objects not be detected.

- Press SET and + pushbuttons contemporarily until the "W\_Ar" text appears.



- Releasing the pushbuttons, the "W\_Ar" text blinks for 2 secs, the sensors acquires the operating area and returns to normal functioning.

##### - Reflective tape specification acquisition

This operation allows the sensor to acquire the specifications of the reflective tape. It is particularly recommended in the "AREA" operating mode due to the high sensitivity of the reflective tape.

- Press SET and - pushbuttons contemporarily until the "tAPE" text appears.



- Releasing the pushbuttons, the "tAPE" text blinks for 2 secs, the sensor memorises the reflective tape specifications and returns to normal functioning.

#### SETTING OF THE PARAMETERS

The operating modes can be set and the delay modified accessing the menu. Press the SET pushbutton until the "MEnu" text appears to access the parameter-programming phase.



Press the + and - pushbuttons to scroll down the parameter list in the following sequence:

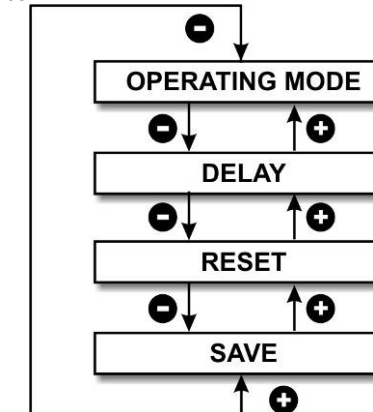

##### - Operating mode selection

The operating mode determines the sensor measurement as indicated in the "FUNCTIONING" paragraph.

- At each SET pushbutton pressure the user cyclically scrolls down the possible operating modes.



##### - Delay setting

DELAY represents the output delay deactivation when the object passes through the area of the two thresholds.

The delay maintains the output activated allowing the sensor interface systems to detect shorter pulses.

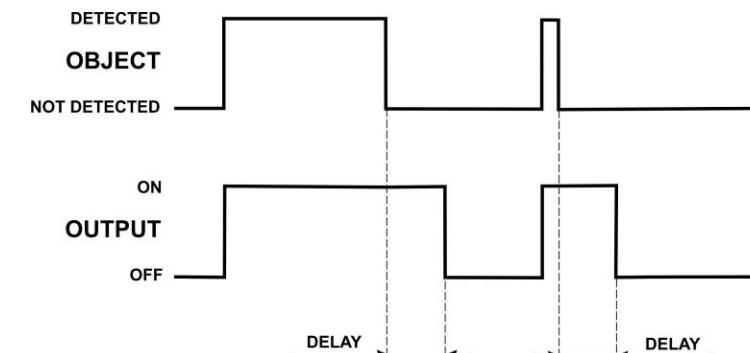

- At each SET pushbutton pressure the user cyclically scrolls down the level options available.

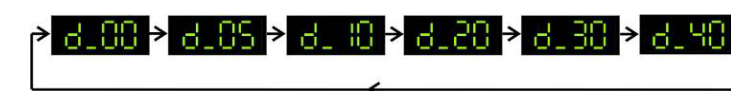

The delay value setting is in common with both outputs.

##### RESET of default parameters

To reset the default parameters, select the "rSEt" text from the parameter menu.



- Pressing the SET pushbutton the "rSEt" text blinks, releasing it the sensor returns to normal functioning.

The reset parameters are: "Object TOP" operating mode, 0 delay, Th1 = 100, Th2 = 200 switching threshold.

##### Memorisation of set "SAVE" parameters

To memorise parameter setting, select the "SAVE" text from the menu.



- Pressing the SET pushbutton, the previously set parameters are memorised and releasing it the sensor returns to normal visualisation.

**Note:** after setting the parameters, exit from the menu with the "SAVE" or "RESET" operation. If these operations are not made within 25 sec from the last setting, the sensor returns to normal mode losing all parameter changes.

### SWITCHING THRESHOLD ACQUISITION

The sensor visualises on the display the measurement acquired according to the operating mode selected. The output is activated when this measurement is included inside the 2 switching thresholds. It may be thus necessary to set the two thresholds: Th1, Th2. The higher threshold has to be acquired first to select the DARK/LIGHT threshold, As shown in the figure (Th1>Th2).

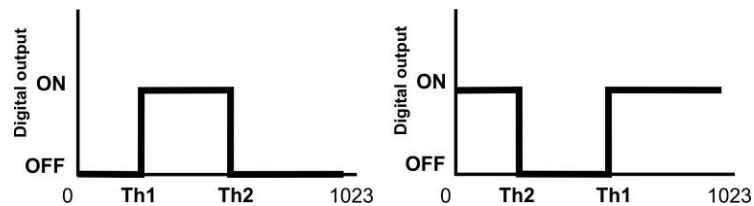

Position object in front of reflective tape:

- Press the SET pushbutton until the "SET1" text appears and release it immediately.



- After 2 secs the threshold value is visualised on the display and the output LED begins to blink, Move the object until reaching the satisfactory value.



- Press SET pushbutton.

- The value on the first threshold blinks on the display for 2 secs, wait for the "SET2" text and place the object in the second position.



- Press SET pushbutton.

- The threshold value is visualised on the display and the output LED begins to blink. Move object until reaching the satisfactory value.



- Press SET pushbutton.

- The value on the first threshold blinks on the display for 2 secs, the sensor ends the target acquisition phase and returns to normal functioning.



### SWITCHING THRESHOLD ADJUSTMENT

The sensor switching thresholds can be adjusted as follows:

- Press the + pushbutton until the "Set1" text appears.



- Select the threshold to change pressing the + and - pushbuttons.



- The adjustment phase is accessed by pressing the SET pushbutton. The selected threshold value blinks on the display.



- The threshold value is increased or decreased by pressing the + and - pushbuttons.

- Press the SET pushbutton to set the new threshold value. The sensor returns to normal functioning after visualising the threshold value for 2 secs on the display.

### PARAMETER VISUALISATION

Parameter visualisation allows to rapidly control the parameters selected: operating mode, threshold1, threshold2, operating area and delay.

- Press the - pushbutton for 2 secs. The memorised parameters are visualised sequentially.

The operating area status can be either Full (complete operating area) or Redu (reduced area).

At the end, the sensor returns to normal functioning.

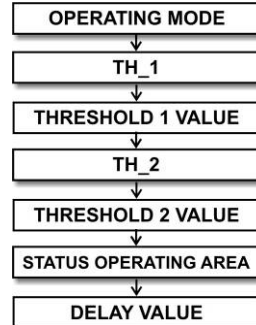

### TRANSPARENT AND REFLECTIVE - OBJECT CHARACTERISATION

For transparent or reflective object detection, the sensor has to be set as follows:

- set AREA mode;
- set threshold1 value at '0';
- set threshold2 value at '1'.

The sensor is thus able to detect transparent or reflective objects inside the measurement line.

### REMOTE FUNCTIONS

#### KEYLOCK function

The keylock function deactivates the keyboard and thus avoids accidental changes in sensor setting.

If the SYNC wire is connected to +Vdc for at least 1 sec. at sensor powering, the keylock function is activated and the pushbuttons are no longer active.

To deactivate the keylock function, the sensor has to be turned off and repowered with the REMOTE wire not connected or connected to 0V.

#### SYNC input

The SYNC signal determines exactly when to activate the sensor detection of objects placed in front of the reflective tape.

The identification cycle begins after the SYNC signal passes from passive to active.

The connection of the SYNC wire to Vdc corresponds to the passive logic status, where SYNC not connected or connected to 0 V corresponds to the active logic status.

(SYNC passive = Vdc ; SYNC active = 0 V).

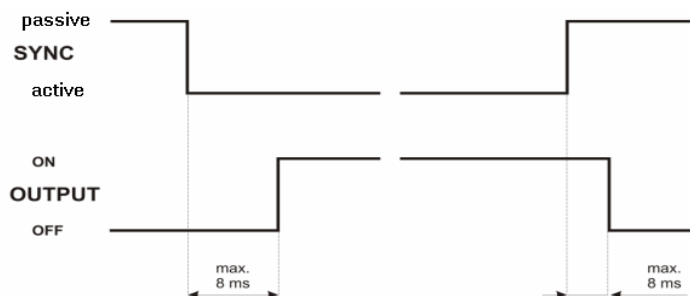

#### RS485 serial connection (only for S65-PA-5-Z09-xxxZ versions)

The complete sensor remote control is obtained using a RS485 line.

All the functions, such as the threshold selection and functioning modes, can be accessed through the serial line.

The serial communication parameters are: 9600 baud, non-parity, 8 data bits, 1 stop bit.

All the commands have to be sent via terminal in an ASCII format according to the following instructions.

#### Sensor data receipt:

The sensor configuration and measurement value can be received at any moment (operating mode, delay, threshold1, threshold2).

COMMAND	RESPONSE
r <CR> <LF>	mX <CR> <LF> dY <CR> <LF> c1txxx<CR> <LF> c2txxx<CR> <LF>
v <CR> <LF>	xxxx <CR> <LF>

where xxxx represents the numeric value, X represents the operating mode set (0..4), Y represents the delay (0..5) according to the coding indicated in the given tables, c1 and c2 the thresholds.

#### Remote acquisition mode

The SYNC input has to remain passive for at least 300 ms to access in the remote acquisition mode.

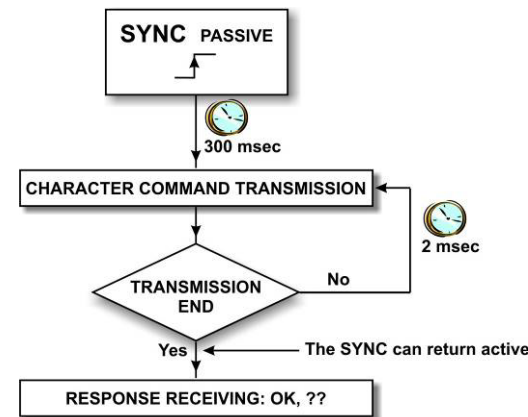

The commands available are:

#### Remote operating area acquisition:

- @ <CR> <LF> beginning of remote acquisition mode (together with passive SYNC)
- w <CR> <LF> operating area acquisition command
- e <CR> <LF> configuration sequence carrying-out
- q <CR> <LF> exit from remote acquisition mode without saving configuration

#### Remote reflective tape specification acquisition:

- @ <CR> <LF> beginning of remote acquisition mode (together with passive SYNC)
- u <CR> <LF> reflective tape specification detection command
- e <CR> <LF> memorisation of the configuration sequence
- q <CR> <LF> exit from remote acquisition mode without saving configuration

If the SYNC input becomes active before the 'e' (execute) command is given, the sensor exits from the remote acquisition mode without saving the configuration, similarly to the receipt of the 'q' (quit) command.

If the SYNC input is active at the receipt of the @ <CR> <LF> command, the sensor replies with ?? <CR> <LF>. At the receipt of the q <CR> <LF> or e <CR> <LF> commands, the sensor returns to ok <CR> <LF>.

#### Sensor configuration

The SYNC input has to remain passive for at least 300 ms to access in the remote acquisition mode. The commands available are:

#### Reset of the sensor default configuration:

- @ <CR> <LF> beginning of remote setting mode (together with passive SYNC)
- z <CR> <LF> default sensor configuration reset command
- e <CR> <LF> memorisation of the configuration sequence
- q <CR> <LF> exit from the remote setting without saving configuration.

#### Switching threshold configuration:

- @ <CR> <LF> beginning of remote acquisition mode (together with passive SYNC)
- cX <CR> <LF> threshold selection, with X ∈ {1,2}
- txxx <CR> <LF> threshold value selection, with xxxx ∈ {0..1023}
- e <CR> <LF> memorisation of the configuration sequence
- q <CR> <LF> exit from remote acquisition mode without saving configuration

#### Operating mode configuration:

- @ <CR> <LF> beginning of remote acquisition mode (together with passive SYNC)
- mx <CR> <LF> operating mode selection, with x ∈ {0, 1, 2, 3, 4}
- m0 = BOTTOM position m3 = width measurement
- m1 = TOP position m4 = area measurement
- m2 = centre position
- e <CR> <LF> memorisation of the configuration sequence.
- q <CR> <LF> exit from remote acquisition without saving the configuration

m0	BOTTOM position
m1	TOP position
m2	Centre position
m3	Width measurement
m4	Area

#### Delay configuration:

- @ <CR> <LF> beginning of remote acquisition mode (together with passive SYNC)
- dx <CR> <LF> delay selection, with x ∈ {0,1,2,3,4,5}
- e <CR> <LF> memorisation of the configuration sequence.
- q <CR> <LF> exit from remote acquisition without saving the configuration

d0	0ms
d1	5ms
d2	10ms
d3	20ms
d4	30ms
d5	40ms

If the SYNC input becomes active before the 'e' (execute) command is given, the sensor exits from the delay configuration without saving, similarly to the receipt of the 'q' (quit) command.

If the SYNC input is active at the receipt of the @ <CR> <LF> command, the sensor replies with ?? <CR> <LF>. At the receipt of the q <CR> <LF> or e <CR> <LF> commands, the sensor returns to ok <CR> <LF>.

**NOTE: the single characters have to be distanced amongst themselves at least 1 ms, during the command transmission.**

#### RS232 serial interface

The sensor can be connected to the RS232 serial using a specific interface adapter.

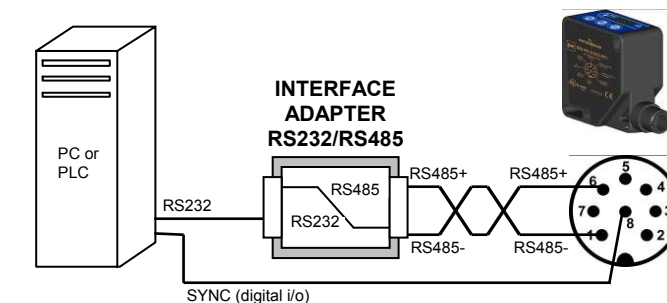

#### DECLARATION OF CONFORMITY

We DATASENSOR S.p.A. declare under our sole responsibility that these products are conform to the 89/336 CEE, 73/23 CEE Directives and successive amendments

#### WARRANTY

DATASENSOR S.p.A. warrants its products to be free from defects. DATASENSOR S.p.A. will repair or replace, free of charge, any product found to be defective during the warranty period of 36 months from the manufacturing date. This warranty does not cover damage or liability deriving from the improper application of DATASENSOR products.

DATASENSOR S.p.A. Via Lavino 265  
40050 Monte S. Pietro - Bologna - Italy  
Tel: +39 051 6765611 Fax: +39 051 6759324  
http://www.datasensor.com e-mail: info@datasensor.com



DATASENSOR S.p.A. cares for the environment: 100% recycled paper. DATASENSOR S.p.A. reserves the right to make modifications and improvements without prior notification.