



SE SERIES

Safety light curtains with infrared beams

SAFEasy™



INSTRUCTION MANUAL

We

DATASENSOR S.p.A.
Via Lavino, 265
40050 Monte San Pietro
Bologna - Italy

declare under our sole responsibility that the product(s)

SE2/SE4-XX-XXX-XX-X,
SAFETY LIGHT CURTAINS -
ELECTRO-SENSITIVE PROTECTIVE EQUIPMENT
(TYPE 2 AND TYPE 4) AND ALL ITS MODELS

to which this declaration relates in conformity with the following
standard(s) or other normative document(s)

CEI EN 55022, JUNE 1997:

LIMITS AND METHODS OF MEASUREMENTS OF RADIO DISTURBANCE OF INFORMATION TECHNOLOGY EQUIPMENT

CEI EN 61000-4-2, SEPTEMBER 1996:

ELECTROMAGNETIC COMPATIBILITY (EMC). PART 4: TESTING AND MEASUREMENT TECHNIQUES. SECTION 2: ELECTROSTATIC DISCHARGE IMMUNITY TEST

CEI EN 61000-4-3, NOVEMBER 1997:

ELECTROMAGNETIC COMPATIBILITY (EMC). PART 4: TESTING AND MEASUREMENT TECHNIQUES. SECTION 3: RADIATED, RADIO-FREQUENCY, ELECTROMAGNETIC FIELD IMMUNITY TEST

CEI EN 61000-4-4, SEPTEMBER 1996:

ELECTROMAGNETIC COMPATIBILITY (EMC). PART 4: TESTING AND MEASUREMENT TECHNIQUES. SECTION 4: ELECTRICAL FAST TRANSIENT/BURST IMMUNITY TEST

CEI EN 61000-4-5, JUNE 1997:

ELECTROMAGNETIC COMPATIBILITY (EMC). PART 4: TESTING AND MEASUREMENT TECHNIQUES. SECTION 5: SURGE IMMUNITY TEST

CEI EN 61000-4-6, NOVEMBER 1997:

ELECTROMAGNETIC COMPATIBILITY (EMC). PART 4: TESTING AND MEASUREMENT TECHNIQUES. SECTION 6: IMMUNITY TO CONDUCTED DISTURBANCES, INDUCED BY RADIO-FREQUENCY FIELDS

CEI IEC 61496-2, NOVEMBER 1997:

SAFETY OF MACHINERY - ELECTRO-SENSITIVE PROTECTIVE EQUIPMENT - PART 2: PARTICULAR REQUIREMENTS FOR EQUIPMENT USING ACTIVE OPTO-ELECTRONIC PROTECTIVE DEVICES (AOPDs)

Following the provision of the Directive(s):

89/336 CEE AND SUCCESSIVE AMENDMENTS

Monte San Pietro, 26/06/2001

Gianni Stradiotti

Quality Assurance Manager



DATASENSOR S.p.A. Via Lavino 265
40050 Monte S. Pietro - Bologna - Italy
Tel: +39 051 6765611 Fax: +39 051 6759324
http://www.datasensor.com e-mail: info@datasensor.com

 DATASENSOR S.p.A. cares for the environment: 100% recycled paper.
DATASENSOR S.p.A. reserves the right to make modifications and improvements without prior notification.

DECLARATION OF CONFORMITY

INDEX

1.	GENERAL INFORMATION	pag. 1
1.1.	General description of the SAFE asy™ safety light curtain	pag. 1
1.2.	How to choose the device	pag. 3
1.3.	Typical applications	pag. 6
1.4.	Safety information	pag. 7
2.	INSTALLATION MODE	pag. 8
2.1	Precautions to be observed for the choice and installation of the device	pag. 8
2.2.	General information on the device positioning	pag. 9
2.2.1.	<i>Minimum installation distance</i>	pag. 11
2.2.2.	<i>Minimum distance from reflecting surfaces</i>	pag. 13
2.2.3.	<i>Installation of several adjacent safety light curtains</i>	pag. 15
2.2.4.	<i>Use of deviating mirrors</i>	pag. 16
3.	MECHANICAL MOUNTING	pag. 17
4.	ELECTRICAL CONNECTIONS	pag. 19
4.1.	Notes on the connections	pag. 20
5.	ALIGNMENT PROCEDURE	pag. 24
5.1.	Correct alignment procedure	pag. 24
6.	FUNCTIONING MODE	pag. 26
6.1.	Dip-switches functioning mode	pag. 26
6.2.	Standard configuration	pag. 26
6.3.	Reset mode	pag. 27
6.4.	Muting function	pag. 29
6.4.1.	<i>Partial muting function</i>	pag. 31
6.5.	Installation mode of the muting sensors	pag. 32
6.6.	Override function	pag. 35
7.	DIAGNOSTIC FUNCTIONS	pag. 36
7.1.	Visualisation of the functions	pag. 36
7.2.	Alignment mode	pag. 37
7.3.	Operating mode	pag. 37
7.4.	Fault and diagnostic messages	pag. 38
8.	CHECKS AND PERIODICAL MAINTENANCE	pag. 39
8.1.	Maintenance	pag. 39
8.2.	General information and useful data	pag. 40
8.3.	Warranty	pag. 40
9.	TECHNICAL DATA	pag. 41
10.	LIST OF THE AVAILABLE MODELS	pag. 42
11.	OVERALL DIMENSIONS	pag. 43

1. GENERAL INFORMATION



1.1. General description of the SAFEasy™ safety light curtain

The **SAFEasy™** safety light curtains – SE Series – are optoelectronic multibeam devices that are used to protect working areas that, in presence of machines, robots and automatic systems in general, can become dangerous for operators that can get in touch, even accidentally, with moving parts.

The **SAFEasy™** devices are type 2 or type 4 intrinsic safety systems, used as accident-prevention protection devices and are manufactured in accordance with the international standards in force for safety, in particular:

CEI EN 61496-1: 1997 Safety of machinery: electro-sensitive protective equipment - General requirements and test.

CEI IEC 61496-2: 1997 Safety of machinery: electro-sensitive protective equipment - Particular requirements for equipment using active optoelectronic protective devices.

The device, consisting in one emitter and one receiver units housed inside strong aluminium profiles, generates infrared beams that detect any opaque object positioned within the light curtains' detection field. The emitter and the receiver units are equipped with the command and control functions; the connections are made through a M12 connector located in the lower side of the profile.

The synchronisation between the emitter and the receiver takes place optically, i.e. no electrical connection between the two units is required. Two microprocessors guarantee the check and the management of the beams that are sent and received through the units: the microprocessors – through some LEDs – give to the operator information about the general conditions of the light curtain and about eventual faults (see section 7 "Diagnostic functions").

During installation, two yellow LEDs facilitate the alignment of both units (see section 5 "Alignment procedures").

As soon as an object, a limb or the operator's body accidentally interrupts the beams sent by the emitter, the receiver immediately opens the OSSD output and blocks the machine (if correctly connected to the OSSD).

N.B.: The following abbreviations will be used in this manual as they are defined by the standards in force:

AOPD Active opto-electronic protective device

ESPE Electro-sensible protective equipment

OSSD Output signal switching device (switching output)

TX Emission device

RX Receiving device

Some parts or sections of this manual containing important information for the operator are preceded by a note:



Notes and detailed descriptions about particular characteristics of the **SAFEasy™** safety devices in order to better explain their functioning; special instructions regarding the installation process.



The information provided in the paragraphs following this symbol is very important for safety and may prevent accidents. Always read this information carefully and follow the advice to the letter.

This manual contains all the information necessary for the selection and operation of the **SAFEasy™** safety devices.





However, specialised knowledge not included in this technical description is required for the planning and implementation of a safety light curtain on a power-driven machine.

As the required knowledge may not be completely included in this manual, the customer is authorised to contact DATASENSOR After Sales Technical Service for any necessary information relative to the functioning of the SE series light curtains and the safety rules that regulate the correct installation (see section 8 "Checks and periodical maintenance").

1.2. How to choose the device

There are at least three different main characteristics that should be considered when choosing a safety light curtain:

- **The resolution** strictly depending on the part of the body to be protected:

R = 14mm	finger protection	
20mm ≤ R ≤ 40mm	hand protection	 
R > 40mm	body protection	 

 The resolution of the device is the minimum dimension which an opaque object must have in order to obscure at least one of the beams that constitute the sensitive area.

As shown in Fig.1, the resolution only depends on the geometrical characteristics of the lenses, diameter and distance between centres, and is independent of any environmental and operating condition of the safety light curtain.

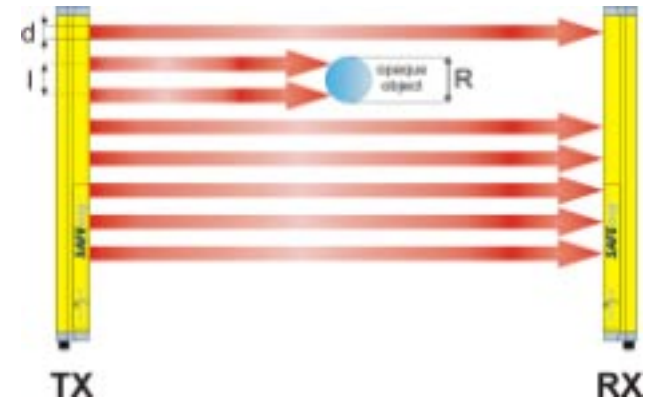

Fig. 1

The following formula is applied to obtain the value of the resolution:

$$R = l + d$$

Fig.2 shows the optical distance between the optic interaxis (I) and the resolution (R), with reference to the safety light curtains destined to the protection of the body.

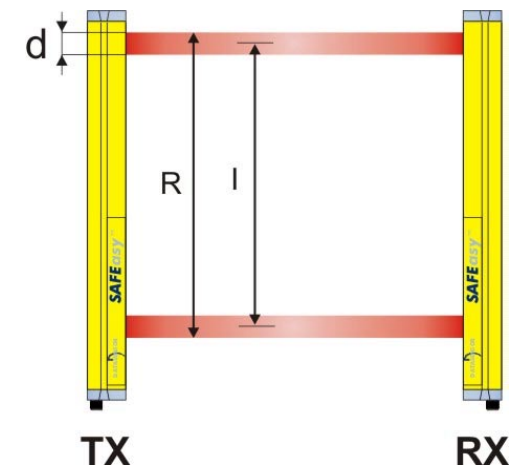

Fig. 2

The values of the safety light curtains for body protection (standard production) are shown in the table.

Model	Optic interaxis mm (I)	N° optics (n)	Resolution mm (R)	Optics Ø mm (d)	Operating distance m
SE*-P2-050	500	2	515	15	50
SE*-P3-080	400	3	415	15	50
SE*-P4-090	300	4	315	15	50
SE*-P4-120	400	4	415	15	50
SE4-Q2-050	500	2	515	15	25
SE4-Q3-080	400	3	415	15	25
SE4-Q4-090	300	4	315	15	25
SE4-Q4-120	400	4	415	15	25

(*) 2 or 4 depending on the safety category.

N.B.: safety light curtains for body protection with height of the sensitive areas and optic interaxis different from the standard versions can be manufactured upon specific request.

- **The height of the protected area**

It is important to distinguish between “Height of the sensitive area” and “Height of the controlled area” (see Fig.3).

- The height of the sensitive area is the distance between the lower and the upper limits respectively of the first and the last lens.
- The height of the controlled area is the effectively protected area; it delimits the area where an opaque object with larger or equal dimensions respect to the resolution of the safety light curtain may certainly cause the darkening of a beam.

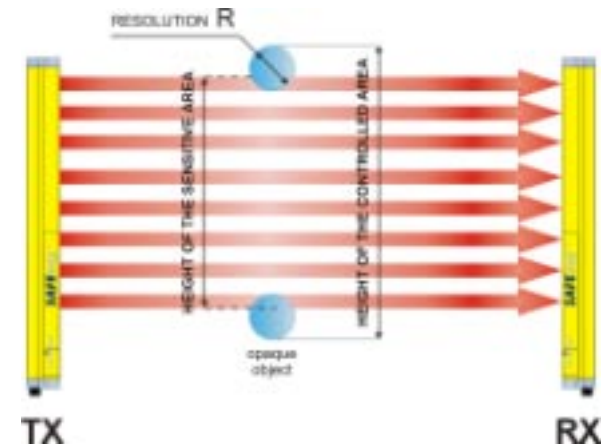

Fig. 3

- **The safety distance**

It is important to carefully calculate the distance between the point where the safety device will be placed and the possible danger associated with the machine to be protected (see *section 2 “Installation mode”* for the calculation of the safety distance).

1.3. Typical applications

The **SAFEasy™** safety light curtains are used in all automation fields where it is necessary to control and protect the access to dangerous zones.

In particular they are used to stop the moving mechanical parts of:

- Automatic machines
- Packaging machines, handling machines, storing machines
- Wood working machines, glass working machines, ceramics working machines, etc.
- Automatic and semi-automatic assembly lines
- Automatic warehouses
- Presses, punching machines, benders and cutters



In food industry applications, it's necessary to verify with DATASENSOR Technical Service the compatibility of the materials of the safety light curtain shell with the eventual chemical agents that are used in the production process.

The following pictures show some main applications.



Automatic packaging machines



Presses and punching machines



Benders and cutters



Conveyor belts

1.4. Safety information



The following points must be observed for a correct and safe use of the **SAFEasy™** safety device:

- The stopping system of the machine must be electrically controllable.
- This control system must be able to instantly stop the dangerous movement of the machine during all the phases of the working cycle.
- Mounting and connection of the safety light curtain must only be carried out by qualified personnel, according to the indications included in the special sections (*refer to sections 2; 3; 4; 5; 6*).
- The safety light curtain must be securely placed in a particular position so that access to the danger zone is not possible without the interruption of the beams (*see section 2 "Installation mode"*).
- The personnel operating in the dangerous area must be well trained and must have adequate knowledge of all the operating procedures of the safety light curtain.
- The TEST/START button must be located outside the protected area because the operator must check the protected area during all the Test, Override and Reset operations.
- The external signalling lamp of the active muting must be visible from any operative side.

2 INSTALLATION MODE

2.1. Precautions to be observed for the choice and installation of the device



- Make sure that the protection level assured by the **SAFEasy™** (2 or 4 type) is compatible with the real danger level of the machine to be controlled, according to EN 954-1.
- The outputs (OSSD) of the ESPE must be used as stopping devices of the machine and not as command devices. The machine must have a special START command.
- The dimension of the smallest object to be detected must be larger than the resolution level of the ESPE.
- The ESPE must be installed in a place compatible with the technical characteristics shown in section 9.
- Do not place the device, in particular the receiver unit, near any intense light sources.
- Strong electromagnetic interferences can compromise the correct functioning of the device. DATASENSOR suggests contacting its own Technical Service when this problem occurs.
- The operating distance of the device can be reduced by 50% in the presence of smog, fog or airborne dust.
- A sudden change in environment temperature, with very low minimum peaks, can generate a small condensation layer on the lenses and so jeopardise functioning.

2.2. General information on the device positioning

The device should be carefully positioned, in order to reach a very high protection standard. Access to the hazardous area must only be possible by passing through the protecting safety light beams.

Fig. 4a shows some examples of possible access to the machine from the top and the bottom sides; these situations may be very dangerous so, it's necessary to install a safety light curtain with a sufficient length to completely cover the access to the dangerous area (Fig. 4b).

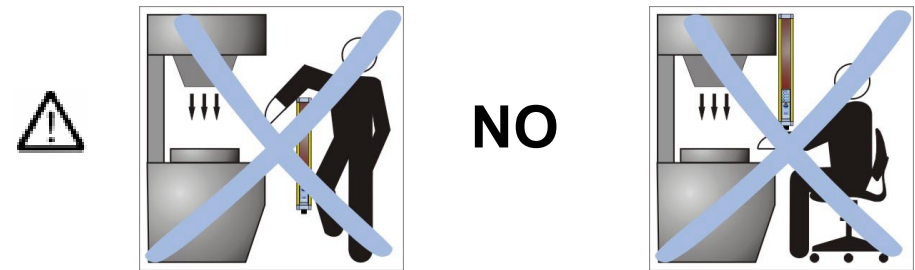

Fig. 4a

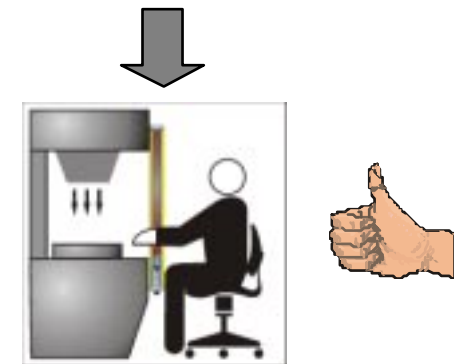

Fig. 4b

However, under normal running conditions, the starting of the machine must not be possible while operators are within the hazard area. When it is not possible to install the safety light curtain in direct proximity to the danger area, it is necessary to place a second light curtain in a horizontal position, in order to prevent any lateral access (as shown in Fig. 5b).

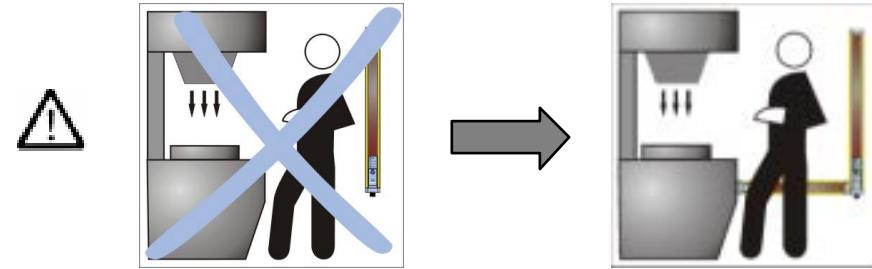



Fig. 5a

Fig. 5b

 If the operator is able to enter the danger area and is not intercepted by the beams, it is necessary to install an additional mechanical protection.

2.2.1. Minimum installation distance

The **SAFEasy™** safety device must be placed according to a specific safety distance (Fig.6); this distance must ensure that the danger zone cannot be reached before the dangerous motion of the machine has been stopped by the ESPE.

The safety distance depends on 4 factors, according to the EN-999, 775 and 294 standards:

- 1 Response time of the ESPE (the time between the effective interception of the beams and the opening of the OSSD contacts).
- 2 Machine stopping time (the time between the effective opening of the contacts of the ESPE and the real stop of the dangerous movement of the machine).
- 3 ESPE resolution.
- 4 Approach speed of the object to be intercepted.

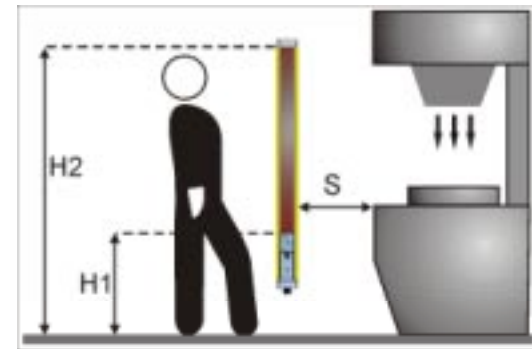

Fig. 6

The following formula is used for the calculation of the safety distance:

$$S = K (t_1 + t_2) + 8 (d - 14)$$

Where:

S = Minimum safety distance in mm.

K = Speed of the object, limb or body approaching the dangerous area in mm/sec.

t₁ = Response time of the ESPE in seconds (see section 9 "Technical data")

t₂ = Machine stopping time in seconds.

d = Resolution of the system.

N.B.: The v value of K is:

2000 mm/s if the calculated value of S is \leq 500 mm

1600 mm/s if the calculated value of S is $>$ 500 mm

When it is possible to reach the dangerous area through the upper and lower sides of the machine, the upper beam must be positioned at the height of 900 mm (H2) above the base of the machine; the lower beam must be positioned at the height of 300 mm (H1).

If the safety light curtain must be placed in a horizontal position (Fig.7), the distance between the dangerous area and the most distant optic beam must be equal to the value calculated using the following formula:

$$S = 1600 \text{ mm/s } (t_1 + t_2) + 1200 - 0.4 H$$

Where:

S = minimum safety distance in mm

t₁ = Response time of the ESPE in seconds (see section 9 "Technical data")

t₂ = Machine stopping time in seconds

H = Height of the beam above the floor; this height must be included between a minimum of 225 mm and a maximum of 1000 mm in order to prevent any possible access from the upper side of the safety light curtain.

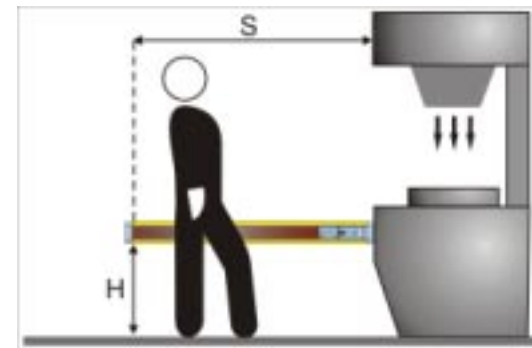

Fig.7

2.2.2. Minimum distance from reflecting surfaces

Reflecting surfaces placed near the light beams of the **SAFEasy™** device (over, under or laterally) may cause passive reflections; these reflections could compromise the recognition of an object inside the controlled area (see Fig. 8).

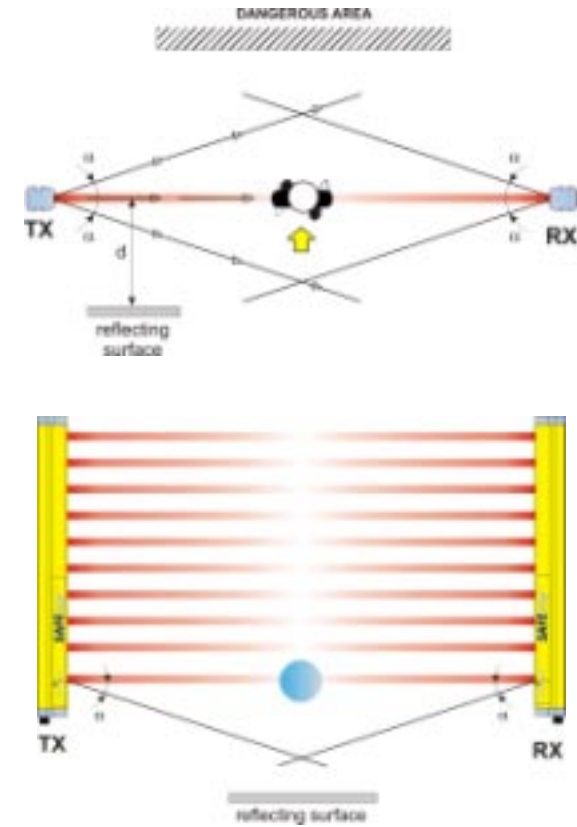

Fig. 8

However, if the **RX** Receiver detects a secondary beam (reflected by the side-reflecting surface) the object cannot be detected, even if the main beam is interrupted by the penetrating object.

It is thus important to position the safety light curtain according to the minimum distance from any reflecting surface.

The minimum distance depends on:

- Operating distance between emitter (**TX**) and receiver (**RX**);
- Maximum opening angle of the light beam sent by the safety light curtain, depending on the type of the device; in particular:
 - 5° for ESPE type 4 ($\pm 2.5^\circ$ as to the optic axis);
 - 10° for ESPE type 2 ($\pm 5^\circ$ as to the optic axis)

The graphic in Fig. 9 shows the data of the minimum distance.

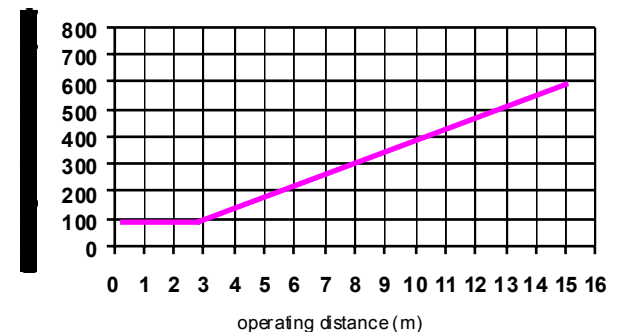

ESPE
type 4

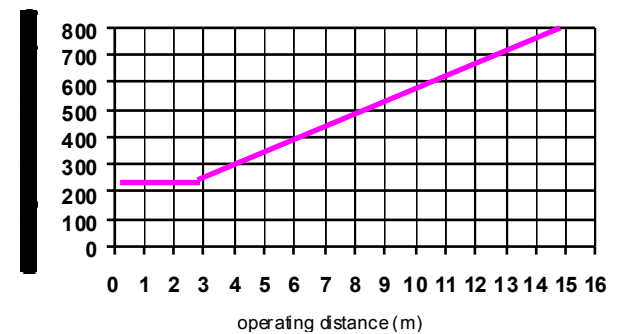

ESPE
type 2

Fig. 9

2.2.3. *Installation of several adjacent safety light curtains*

When several safety devices must be installed in adjacent areas, it's necessary to prevent the interferences between the emitter of one device and the receiver of another.

Fig.10 gives an example of possible interferences between different devices and two pertinent solutions.

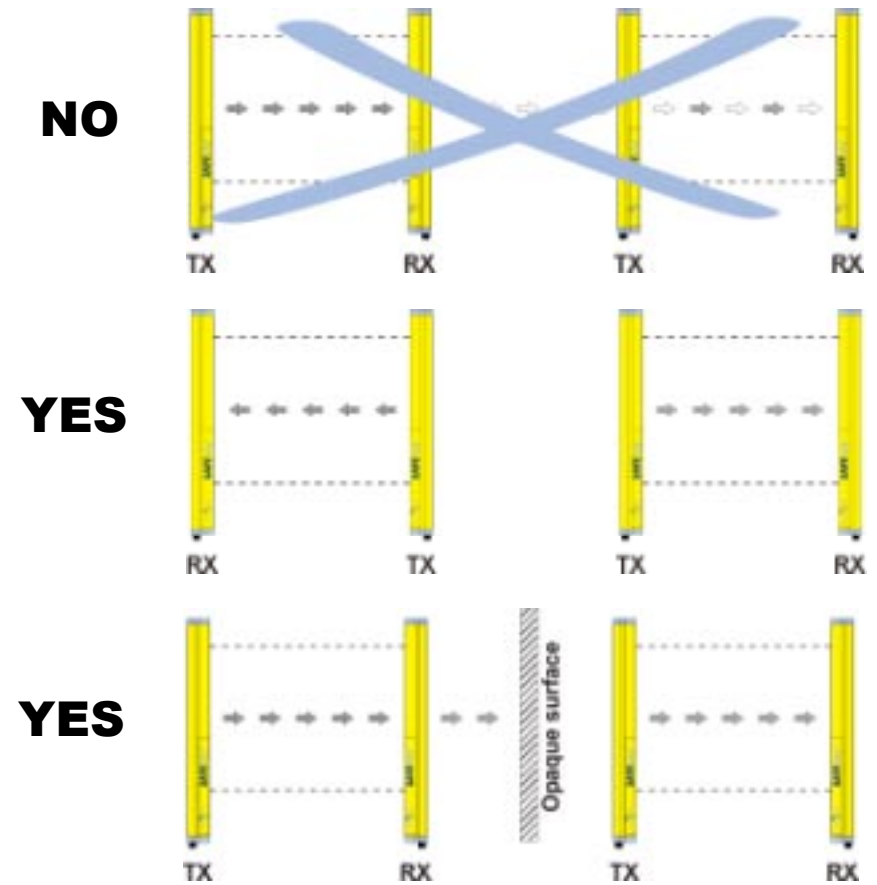

Fig.10

2.2.4. Use of deviating mirrors

The control of any dangerous area, with several but adjacent access sides, is possible using only one **SAFEasy™** light curtain and well-positioned deviating mirrors.

Fig.11 shows a possible solution to control three different access sides, using two mirrors placed at a 45° angle respect to the beams.

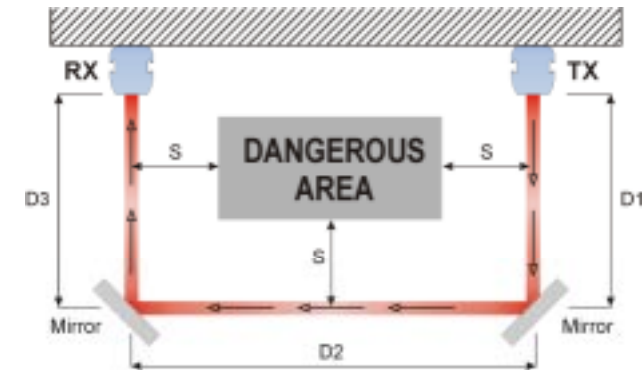

Fig. 11

The operator must observe the following precautions when using the deviating mirrors:

- The alignment of the emitter and the receiver may be a very critical operation when the deviating mirrors are used; a very small angular displacement of the mirror is enough to loose the alignment. A laser pointer (available as an accessory) can be used to avoid this problem.
- The minimum safety distance (S) must be respected for each single section of the beams.
- The effective operating range – sum of the different sections of the beams ($D1 + D2 + D3$) – decreases by about 10-15% for each mirror.
- The eventual presence of dust or dirt on the reflecting surface of the mirror causes a drastic reduction in the range.
- Do not use more than three mirrors for each device.

3. MECHANICAL MOUNTING

The emission (TX) and receiving (RX) bars must be installed with the relevant sensitive surfaces turned toward each other; the connectors must be positioned on the same side and the distance must be included within the operating range of the model used (see *section 9 "Technical data"*).

Once they have been positioned, the two bars should be aligned and parallel as much as possible.

The next step is the fine alignment, as shown in *section 5 "Alignment procedures"*.

To mount the device, use the threaded pins supplied; insert them into the slots on the two bars (Fig.12).

The operator can use the pins and/or the rigid mounting brackets – supplied with the device – depending on the particular application and/or the type of support on which the two bars must be placed (see Fig.13).



Fig.12



Fig. 13

Rigid brackets can be used where no large mechanical tolerances require compensation, during the alignment operation.

The rotating supports for the correction of the bars' inclination are available on request.

In case of applications with particularly strong vibrations, it is advisable to use some anti-vibration shock absorbers with the capacity to reduce the impact of the vibrations – together with threaded pins, rigid brackets and/or rotating supports.

The recommended mounting positions according to the length of the safety light curtain are shown in the following drawing and table:

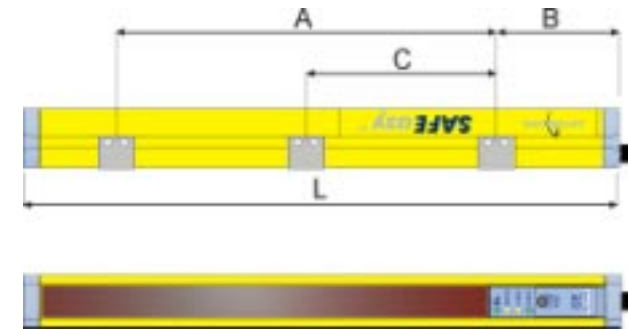

MODEL	L (mm)	A (mm)	B (mm)	C (mm)
SE*-YY-015-PP-W	246	86	80	-
SE*-YY-030-PP-W	393	193	100	-
SE*-YY-045-PP-W	540	300	120	-
SE*-YY-060-PP-W	687	387	150	-
SE*-YY-075-PP-W	834	474	180	-
SE*-YY-090-PP-W	981	581	200	-
SE*-YY-105-PP-W	1128	688	220	-
SE*-YY-120-PP-W	1275	875	200	438
SE*-YY-135-PP-W	1422	1022	200	510
SE*-YY-150-PP-W	1569	1121	220	565
SE*-YY-165-PP-W	1716	1216	250	688
SE*-P2-050-PP-W	642	342	150	-
SE*-P3-080-PP-W	942	542	200	-
SE*-P4-090-PP-W	1042	602	220	-
SE*-P4-120-PP-W	1342	942	200	472
SE4-Q2-050-PP-W	642	342	150	-
SE4-Q3-080-PP-W	942	542	200	-
SE4-Q4-090-PP-W	1042	602	220	-
SE4-Q4-120-PP-W	1342	942	200	472

(*) 2 or 4 depending on the safety class

YY Resolution (14 = fingers; 35 = hands)

4. ELECTRICAL CONNECTIONS

Every electrical connection to the emitter and receiving units is made through a male M12 connector, located in the lower part of the safety light curtain.

A M12 8-pole connector is used for the receiver and a M12 4-pole connector for the emitter.

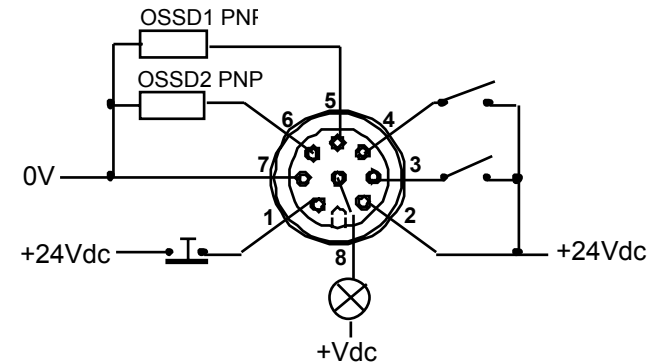

RECEIVER (RX):

- | | |
|------------|--------------|
| 1 = white | = TEST/START |
| 2 = brown | = +Vdc |
| 3 = green | = MUTING 1 |
| 4 = yellow | = MUTING 2 |
| 5 = grey | = OSSD1 1 |
| 6 = pink | = OSSD2 2 |
| 7 = blue | = 0V |
| 8 = red | = LAMP |

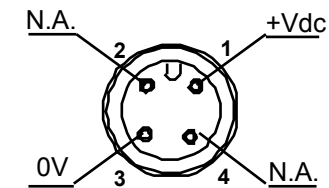

EMITTER (TX):

- | | |
|-----------|--------|
| 1 = brown | = +Vdc |
| 3 = blue | = 0V |

4.1. Notes on the connections

For the correct functioning of the **SAFEasy™** safety light curtain, it is necessary to observe the following precautions regarding the electrical connections:



- Use only shielded cables for the connection of the two units. Fig.14 shows the correct connection of both the units and the cable when ground connection is used.

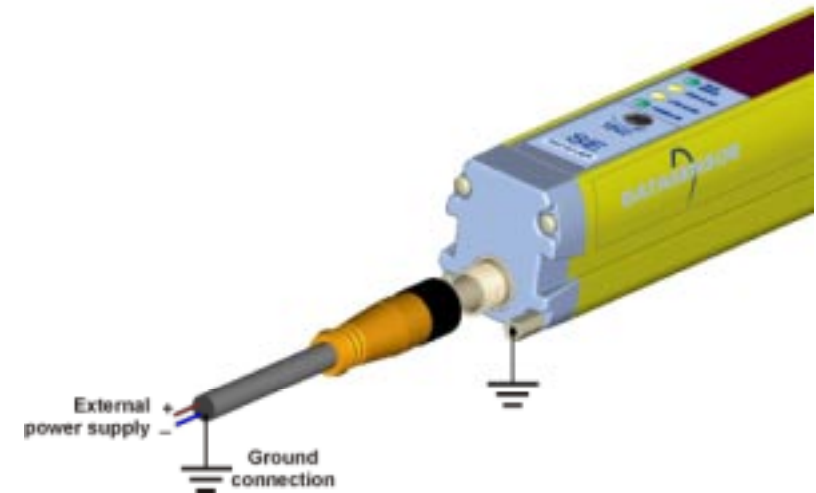



Fig. 14

- These cables must not be placed in contact with or near any high voltage cable (e.g. motor power supply, inverters, etc.); the correct functioning of the safety device can be compromised by the presence of strong electro-magnetic fields.
 - The TEST/START wire must be connected through a N.C. button to the supply voltage of the ESPE. A daily manual test is necessary to verify the correct functioning of the safety light curtain; push the relevant button to activate the test.
-  • The TEST/START button must be located in such a way that the operator can check the protected area during any test, override and reset operation. (see section 6 "Functioning mode").



- Put one fuse with rated interruption current 500 mA between the connection of the external signalling lamp of active muting and the RX unit. The signalling lamp should be placed in such a way that it can be seen from every operative side.

Read the “Functioning mode” section 6 that shows the muting function, its use and how to position the activation sensors of this function.

N.B.: If the muting devices (muting sensors and muting lamp) are not used, the 3, 4 and 8 cable pins of the receiver must be electrically insulated.



- The safety contacts OSSD1 and OSSD2 cannot be connected in series or in parallel; both can be used separately (Fig.15). If one of these configurations is wrongly used (Fig.16, 17, 18), the device enters into the output failure state (see *cap.7 "Diagnostic functions"*).

If only one OSSD is used, the system loses its safety category (from type 4 to type 2).

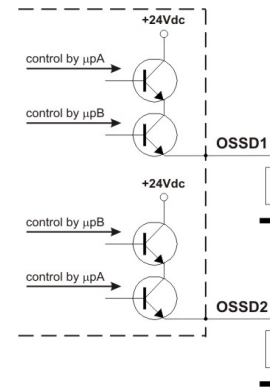

Fig. 15

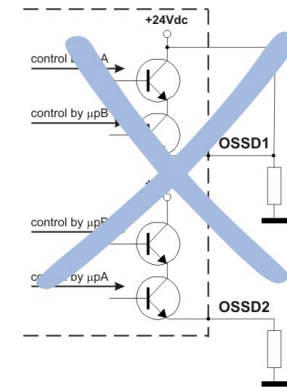

Fig. 16

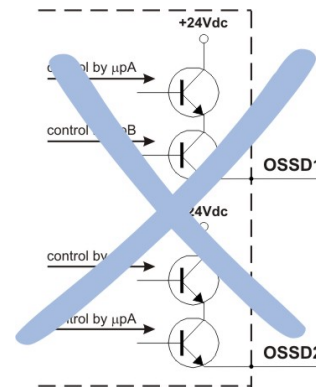

Fig. 17

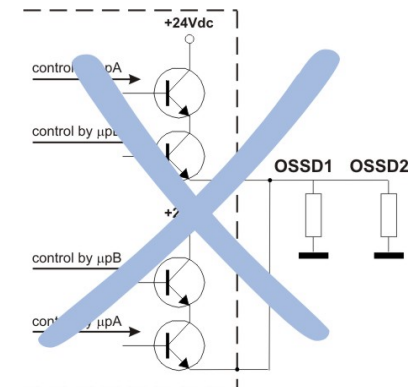



Fig. 18

-  The ground connection of the two units is not necessary. However, if required, the connection is possible; tighten the special screw – supplied with the device – instead of one of the 8 screws that lock the heads of each bar (see Fig. 19). Respect the connection illustrated in page 20 (Fig. 14) when ground connection of the entire system is used.

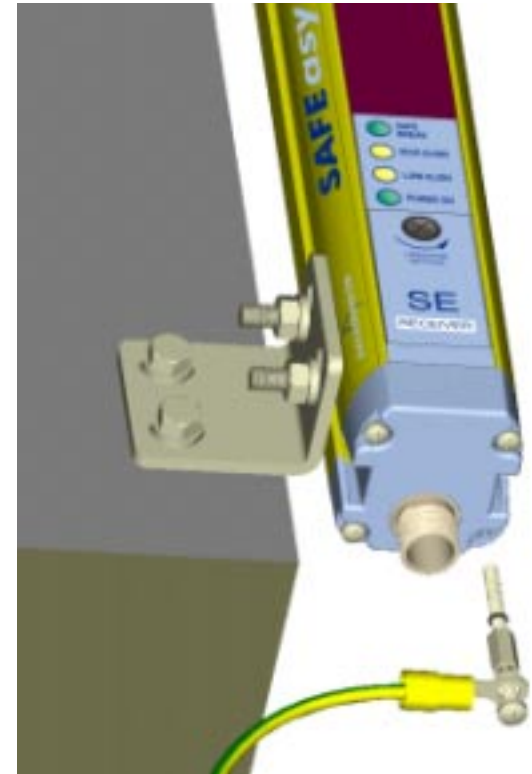

Fig. 19

5. ALIGNMENT PROCEDURES

The alignment between the emitter and the receiver units is necessary to obtain the correct functioning of the light curtain.

The alignment is perfect if the optic axes of the first and the last emitter beam coincide with the optic axes of the corresponding elements of the receiver unit. Two yellow LED indicators (HIGH ALIGN, LOW ALIGN) facilitate the alignment procedure.

5.1. Correct alignment procedure

When the mechanical installation and the electrical connections have been accomplished – as explained in the previous paragraphs – it is possible to execute the alignment of the safety light curtain, according to the following procedure:

- Disconnect the power supply to **SAFEasy™**.
- Press the TEST/START button and keep it pressed (open the contact).
- Re-connect the power supply.
- Release the TEST/START button.
- Check the green LED on the bottom of the TX unit (POWER ON) and the yellow LED (SAFE); if they are ON, the unit is running correctly.
- Verify that one of the following conditions is present on the RX unit:
 1. The green LED on the bottom is ON (POWER ON) and the light of the SAFE/BREAK LED on the top is red (BREAK): non-alignment condition.
 2. The green LED on the bottom is ON (POWER ON) and the light of the SAFE/BREAK LED on the top is green (SAFE): aligned units condition (in this case also the two intermediate yellow LED HIGH ALIGN, LOW ALIGN, are ON);
- Go on with the following steps to change from condition 1 to condition 2:
 - A** Keep the receiving unit in a steady position and set the transmission unit until the yellow LED on the bottom (LOW ALIGN) is ON: this condition shows the effective alignment of the first lower beam.

B Rotate the transmission unit until the upper yellow LED (HIGH ALIGN) is ON: in this condition the upper LED must change from BREAK to SAFE (from red to green).

N.B.: Make sure that the green light of the LED is ON and steady.

C Delimit the area in which the SAFE LED is steady through some micro adjustments - for the first and then for the second unit - then place both units in the centre of this area.

- Fix the two units firmly using pins and brackets.
- Disconnect the power supply to **SAFEasy™**.
- Reconnect the power supply.
- Verify that the LED is ON – green light – on the RX unit: in that condition the beams are free, SAFE; then verify that the same LED is ON – red light – if one single beam is obscured: in that condition an object has been intercepted, BREAK.
- It is important to do this check through the special cylindrical “Test Piece” with a diameter adequate for the resolution of the used device (14 mm or 35 mm).

N.B.: When the Test Piece is passed – from the top to the bottom – through the full sensitive area at any distance from the two units, the BREAK LED must always stay ON – red light – without any spurious commutation.

It is advisable to execute this test every day.

6. FUNCTIONING MODE

6.1. Dip-switches functioning mode

A slot situated in the front side of the RX unit, that can be easily opened using a screwdriver, facilitates the access to the internal dip-switches for the configuration of:

- reset mode
- total muting function
- partial muting function



The device does not accept configuration changes during normal functioning. A change is accepted only beginning from the successive powering of the device. Particular attention has to be taken during the management and use of the configuration dip-switches.

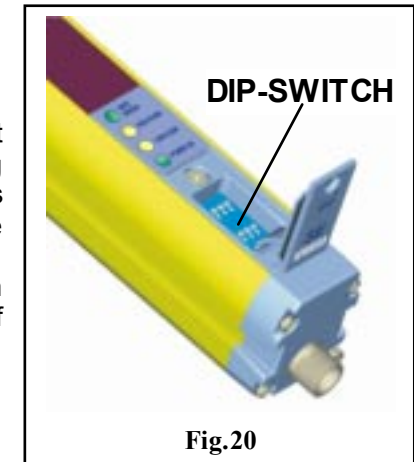

Fig.20

6.2. Standard configuration

The device is supplied with the following standard configuration:

- automatic reset
- total active muting

N.B.: The muting function can be activated only if the muting1 and muting2 inputs and the muting lamp are connected correctly.

For further details of these functions see sections 6.3 and 6.4.

6.3. Reset mode

The beams sent by the emitter unit that intercept an opaque object cause the switching of the OSSD outputs – opening of the safety contacts: BREAK condition.

The reset of the normal functioning of the ESPE – dosing of the OSSD safety contacts; SAFE condition – can be accomplished in two different ways:

- **Automatic Reset:** when an opaque object is detected, the ESPE starts to work; then, after the opaque object has been removed from the controlled area, the ESPE begins its normal functioning again.
- **Manual Reset:** after the ESPE has detected an opaque object in the controlled area, the light curtain begins its normal functioning again only by pressing the reset button (TEST/START key) and after the object has been removed from the controlled area.

The Fig.20 below shows these two functioning modes.

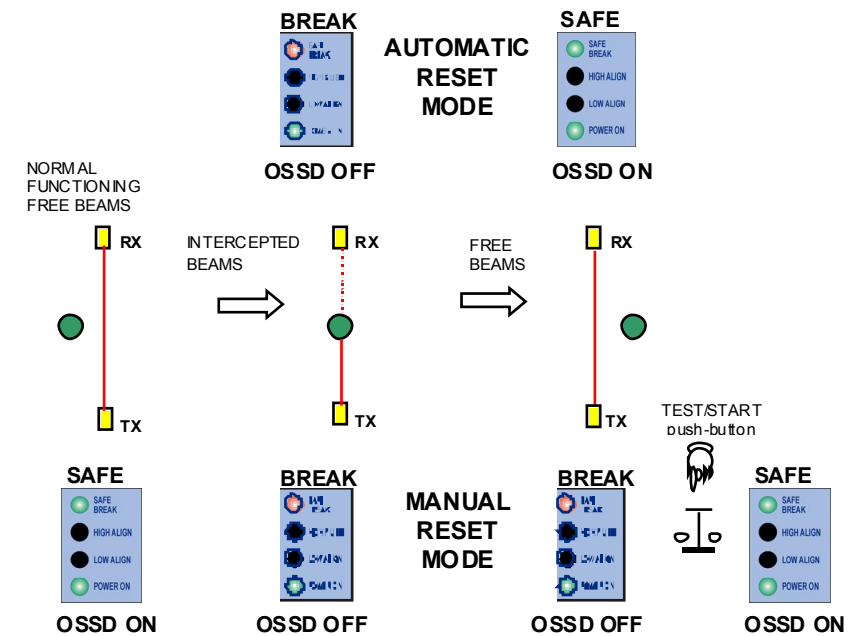
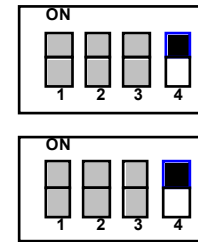

Fig. 21

The selection of the manual / automatic Reset mode is made through the dip-switches placed under the slot of the receiving unit (see Fig.21).

In particular, the position 4 of both switches must be ON to have automatic reset mode; OFF to have manual reset mode.



N.B.: The dip-switches not used for this function are grey; the position of the lever of the special dip-switch is in black (automatic reset mode).

6.4. Muting function

- In relation to particular operating requirements, the muting function enables the exclusion of the safety light curtain during functioning; all OSSD outputs stay active (Fig.22).

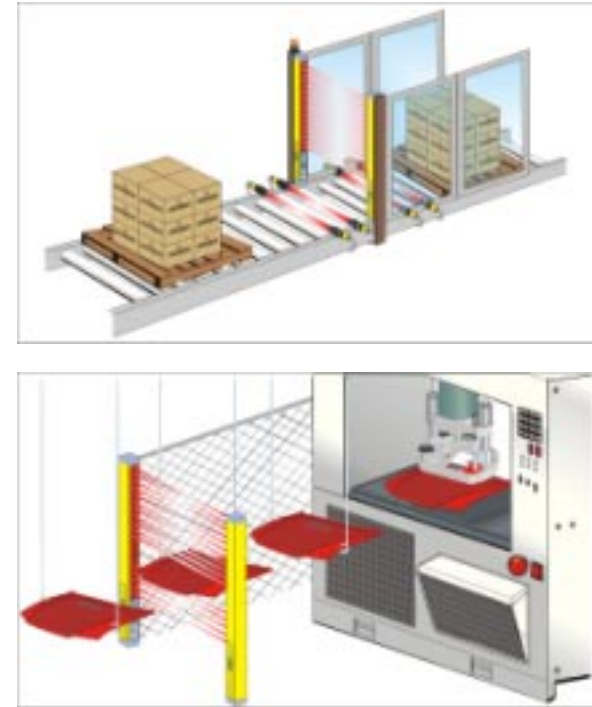

Fig. 22

The safety light curtain, according to the standards in force, is equipped with two inputs – muting1 and muting2 – for the activation of this function.

- This function is particularly suitable when an object and not a person has to pass through the dangerous area, under certain conditions.
- It is important to remember that the muting function is a forced situation for the system; therefore, it should be used with necessary precautions.

- Two muting sensors enable the inputs MUTING1 and MUTING2; these two sensors should be correctly connected and positioned, in order to avoid undesired muting or potentially dangerous conditions for the operator.



In order to enable the muting function it is necessary to connect the external muting signalling lamp; if the lamp is not connected, the ESPE stops. If the muting lamp is not connected, the muting or override request causes the opening of the safety contacts and the device is blocked due to the lamps anomaly (see 7.4 “*Fault and diagnostic messages*”).

The Fig.23 shows an example of muting functioning.

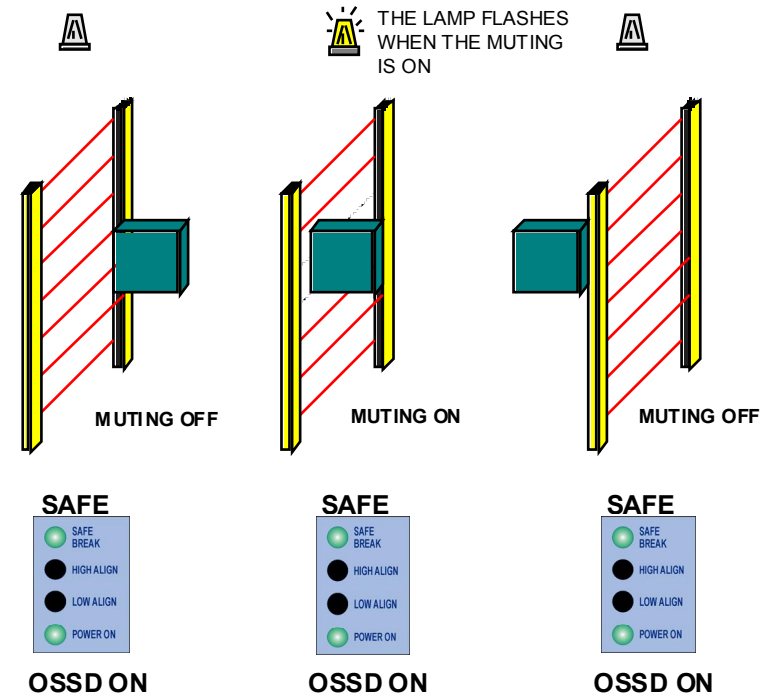

Fig. 23

6.4.1. Partial muting function

The SE series safety light curtains are equipped with an auxiliary partial muting function that deactivates selected zones inside the sensible area.

This function makes it possible to check 4 different zones (or optic groups) separately inside the sensitive area.

The width and the covering – total or partial – of the sensitive area change depending on the height and resolution of the light curtain used.

The control of the functioning inhibition of the 4 selected zones leads to different possibilities:

- Separate inhibition of the 4 zones – one by one – (the first area begins from the lower part of the light curtain: connector side).
When the 4° zone includes the upper beam of the light curtain, that beam will not accept the partial muting. It will continue to function as it is the responsible of the optical synchronisation between TX and RX units.
- Inhibition of groups of zones; in particular: 1° + 2° zone; 1° + 2° +3° zone; 1° + 2° +3° + 4° zone.
- Inhibition of the full sensitive area = total muting.

The desired configuration can be obtained using the two dip-switches positioned on the receiver unit.

The table below shows the possible configurations depending on the different **SAFEasy™** models.

Muting Zones for partial/total Muting			1	2	3	4	1+2	1+2+3	1+2+3+4	TOTAL
DIP SWITCHES setting for the control of partial/total Muting										
Model	N° optics	N° of inhibited optics by part. Muting (1-4)	inhibited optics	inhibited optics	inhibited optics	inhibited optics	inhibited optics	inhibited optics	inhibited optics	inhibited optics
SE4-14-015-X	21	1°..12°	1°..3°	4°..6°	7°..9°	10°..12°	1°..6°	1°..9°	1°..12°	1°..21°
SE4-14-030-X	42	1°..24°	1°..6°	7°..12°	13°..18°	19°..24°	1°..12°	1°..18°	1°..24°	1°..42°
SE4-14-045-X	63	1°..36°	1°..9°	10°..18°	19°..27°	28°..36°	1°..18°	1°..27°	1°..36°	1°..63°
SE4-14-060-X	84	1°..56°	1°..14°	15°..28°	29°..42°	43°..56°	1°..28°	1°..42°	1°..56°	1°..84°
SE4-14-075-X	105	1°..60°	1°..15°	16°..30°	31°..45°	46°..60°	1°..30°	1°..45°	1°..60°	1°..105°
SE24-35-015-X	6	1°..7°	1°..2°	3°..4°	5°..6°	7°	1°..4°	1°..6°	1°..8°	1°..8°
SE24-35-030-X	18	1°..15°	1°..4°	5°..8°	9°..12°	13°..15°	1°..8°	1°..12°	1°..16°	1°..16°
SE24-35-045-X	24	1°..23°	1°..6°	7°..12°	13°..18°	19°..23°	1°..12°	1°..18°	1°..24°	1°..24°
SE24-35-060-X	32	1°..31°	1°..8°	9°..16°	17°..24°	25°..31°	1°..16°	1°..24°	1°..32°	1°..32°
SE24-35-075-X	40	1°..32°	1°..8°	9°..16°	17°..24°	25°..32°	1°..16°	1°..24°	1°..32°	1°..40°
SE24-35-090-X	48	1°..32°	1°..8°	9°..16°	17°..24°	25°..32°	1°..16°	1°..24°	1°..32°	1°..48°
SE24-35-105-X	56	1°..32°	1°..8°	9°..16°	17°..24°	25°..32°	1°..16°	1°..24°	1°..32°	1°..56°
SE24-35-120-X	64	1°..63°	1°..16°	17°..32°	33°..48°	49°..63°	1°..32°	1°..48°	1°..64°	1°..64°
SE24-35-135-X	72	1°..48°	1°..12°	13°..24°	25°..36°	37°..48°	1°..24°	1°..36°	1°..48°	1°..72°
SE24-35-150-X	80	1°..64°	1°..16°	17°..32°	33°..48°	49°..64°	1°..32°	1°..48°	1°..64°	1°..80°
SE24-35-165-X	88	1°..87°	1°..22°	23°..44°	45°..66°	67°..87°	1°..44°	1°..66°	1°..88°	1°..88°
SE24-P/Q2-050-X	2	1°	1°	-----	-----	-----	1°..2°	-----	-----	1°..2°
SE24-P/Q3-090-X	3	1°..2°	1°	2°	-----	-----	1°..2°	1°..3°	-----	1°..3°
SE24-P/Q4-090-X	4	1°..3°	1°	2°	3°	-----	1°..2°	1°..3°	1°..4°	1°..4°
SE24-P/Q4-120-X	4	1°..3°	1°	2°	3°	-----	1°..2°	1°..3°	1°..4°	1°..4°

6.5. Installation mode of the muting sensors

The muting sensors must be able to recognize the passing material (pallets, vehicles, ...) according to the material's length and speed.



In the case of different transportation speeds in the muting area, it is necessary to consider their effect on the total muting duration.

Fig.24 shows how to install an **SAFEasy™** light curtain placed on a conveyor, with the relative muting sensors.

The muting activation sensors A1, A2, B1, B2 temporarily inhibit the ESPE if a package passes between the sensors; the outputs of these sensors are connected to the muting1 and muting2 inputs of the receiver unit of the ESPE.

The contacts of these sensors are controlled by the receiver unit.

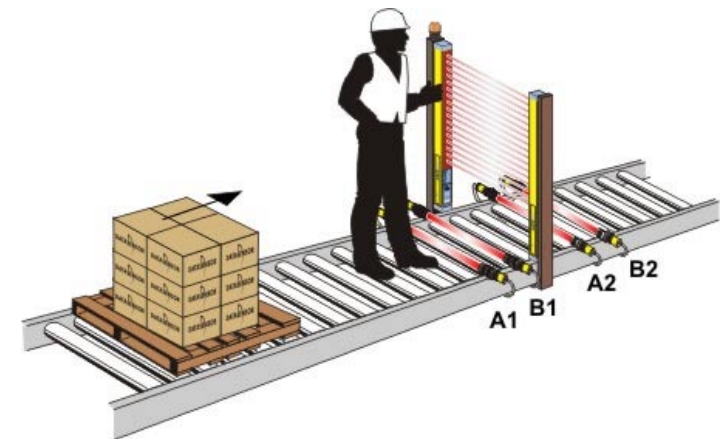
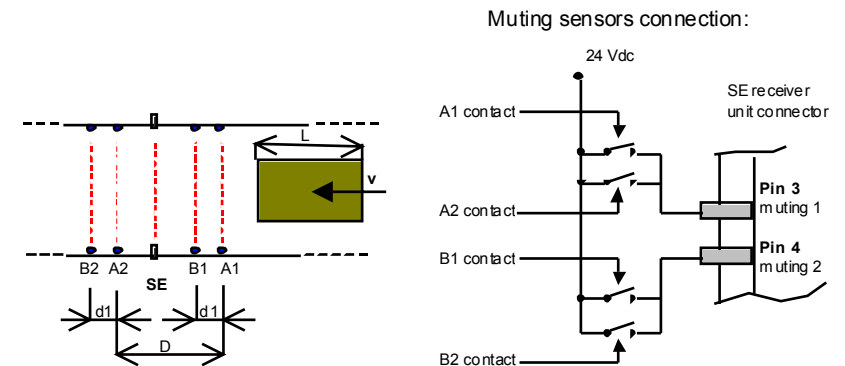

Fig. 24

Optoelectronic, mechanical, proximity sensors etc, can be used as muting sensors, with closed contact in the presence of the object to be detected.

The following are some configuration examples when using the muting function:

- **Application with four optoelectronic sensors:**



D: minimum distance required for the *muting* sensors to maintain the request active; it depends on the length of the package: $D < L$

d₁: distance required for the muting request to be accepted; this distance is relative to the speed of the package:

$$d_{1\max} [\text{cm}] = v[\text{m/s}] * 0.5[\text{s}] * 100$$

$$d_{1\min} [\text{cm}] \geq 0.1$$

- **Application with two optoelectronic sensors:**

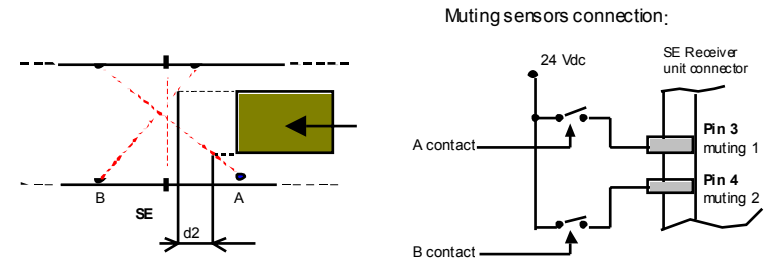

- d_2 : distance required for the muting request to be accepted; this distance is relative to the speed of the package:
 $d_{2max} [cm] = v[m/s] * 0.5[s] * 100$
 d_{2min} should be such that the intersection point of the beams of the two sensors are inside the area controlled by the ESPE.



- The muting sensors must be positioned in such a way that the activation of the muting function is not possible with the accidental passing of a person.
- The muting request should be made activating the muting 1 first, then of muting 2 – or vice versa.
- Both activations should be carried out according to an exact temporal sequence: the second activation should occur within 0,5 sec. after the first one; otherwise, the muting will not be active.
- Any muting request can not be made if the ESPE is in BREAK condition (right LED is ON, the beams are intercepted).

6.6. Override function

This function makes it possible to force a muting condition when the reset of the machine is necessary, even if one or more beams are interrupted by passing material.

The purpose is to clear the protected area of any eventual material accumulated in consequence of an anomaly in the working cycle.

For example, if one pallet stops in front of the protected area, the conveyor may not be restarted because the ESPE (that has one or more interrupted beams) will open the OSSD outputs and will not permit to clear the controlled area.

The activation of the override function makes it possible to carry out this operation.

- *Activation of the override function*

- Switch OFF the device.
- Switch ON the device.
- To activate the override function, press the TEST/START button within 10 seconds after turning the device on and keep it pressed for at least 5 seconds;
- Keep the button pressed until the clearing of the protected area has been completed;
- When the override function is ON, the external muting indicator signal flashes indicating the exclusion of the safety device;
- The maximum length of the override function is 120 sec.; after that time, the ESPE returns to normal functioning, even if the TEST/START button is pressed. Obviously, if the button is released within the 120 seconds, the override function immediately stops.

N.B.: The external active muting or override signalling lamp must be visible from every operative side.

7. DIAGNOSTIC FUNCTIONS

7.1. Visualization of the functions

The operator can visualize the operating condition of the light curtains through four LEDs positioned on the receiver unit and two LEDs on the emitter unit (Fig.25).



Fig. 25

The reason for the LEDs positioned on the receiver unit (**RX**) depends on the functioning mode of the safety light curtain.

7.2 Alignment mode

In this condition the outputs are OFF.

- **SAFE/BREAK LED:**
SAFE GREEN LED when **ON** it shows that no objects have been intercepted by the device.
BREAK RED LED when **ON** it shows that the receiver and the emitter units are not aligned, or that an object has been intercepted.
- **ALIGN HIGH LED: (yellow)** when **ON**, it shows the correct alignment of the last TX optic with the corresponding RX optic (upper side of the device).
- **ALIGN LOW LED: (yellow)** when **ON**, it shows the correct alignment of the first TX optic with the corresponding RX optic (lower side of the device).
- **POWER ON LED: (green)** when **ON**, it shows that the unit is correctly supplied.

7.3 Operating mode

- **SAFE/BREAK LED:**
SAFE GREEN LED when **ON** it shows that no objects have been intercepted by the device.
BREAK RED LED when **ON** it shows that one object has been intercepted; in this condition the outputs are OFF.
- **ALIGN HIGH LED: (yellow)** when **continuously ON** it shows that it is necessary to press the TEST/START button to reset the device in consequence of an object interception. This occurs only when the device runs under the manual reset mode.
- **ALIGN LOW LED: (yellow)** when **continuously ON** it shows the presence of dust on the emitter and/or receiver surfaces. This signalling is only a warning; the device continues to operate.
- **ALIGN LOW LED: (yellow)** when **blinking** it shows the presence of a short-circuit on the outputs. This signalling is only a warning; the device continues to operate.





The LEDs located on the emitter (**TX**) have the following meanings:

- **SAFE LED (yellow):** when **ON**, it shows that the unit is emitting correctly.
- **POWER ON LED (green):** when **ON**, it shows that the unit is correctly supplied.

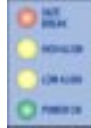

7.4. Fault messages and Diagnostics

The operator is able to check the main causes of stop and breakdown of the system, using the same LEDs used for the visualization of the functions.

RECEIVER UNIT:

Breakdown	Cause	Check and Repair
 Red blinking Yellow blinking Green ON	Anomaly on the output	<ul style="list-style-type: none"> - Check the output connections. - Contact DataSensor in case a capacitive load > 0.1µF is not connected
 OFF Yellow blinking Green ON	Anomaly of the microprocessor	<ul style="list-style-type: none"> - Switch off and switch on the device. Replace the unit if the anomaly continues
 OFF OFF Yellow blinking Green ON	Optic anomaly	<ul style="list-style-type: none"> - Check the alignment of both units - Switch off and switch on the device. - Replace the unit if the anomaly continues and contact DataSensor
 Green blinking Yellow blinking Green ON	Anomaly of the external muting signalling lamp	<ul style="list-style-type: none"> - Check the integrity of the lamp - Check the connections
 OFF OFF OFF OFF	Power supply failure	<ul style="list-style-type: none"> - Check the power supply.

EMITTER UNIT:

Breakdown	Cause	Check and Repair
 Yellow blinking Green ON	Transmission failure	<ul style="list-style-type: none"> - Check the power supply. - Replace the unit.
 OFF OFF	Power supply failure	<ul style="list-style-type: none"> - Check the power supply.

8. CHECKS AND PERIODICAL MAINTENANCE

The following is a list of recommended check and maintenance operations that should be periodically carried out by qualified personnel.

Check that:

- The ESPE stays locked while intercepting the beams along the entire protected area, using the suitable "Test Piece".
- Pressing the TEST/START button, the OSSD outputs should open (the red BREAK LED is ON and the controlled machine stops).
- The response time at the machine STOP (inclusive of the response time of the ESPE and of the machine) is within the limits defined by the calculation of the safety distance (see section 2 "Installation Mode").
- The safety distance between the dangerous areas and the ESPE are in accordance with the instructions included in section 2 "Installation Mode".
- Access to the dangerous area of the machine from any unprotected area is not possible .
- The ESPE and the external electrical connections are not damaged.

The frequency of checks depends on the particular application and on the operating conditions of the safety light curtain.

8.1. Maintenance

The **SAFEasy™** SE safety devices do not need any particular maintenance, with the exception of the cleaning of the protection frontal surfaces of the optics.

When cleaning, use a cotton cloth dampened with water..



Do not under any circumstances use:

- alcohol or solvents
- wool or synthetic cloths

8.2. General information and useful data



The safety devices fulfil their safety function only if they are correctly installed, in accordance with the standards in force.

If you are not certain as to whether or not you have the necessary expertise to install the device in the correct way, DATASENSOR technical service is at your disposal to carry out the installation.

Auto-regenerating type fuses are used; so, if a short-circuit occurs, these fuses protect the device.

After the intervention of the fuses, it is necessary to disconnect the power supply and wait for 20 seconds, so that the fuses can automatically restart normal functioning.

A power failure caused by interferences may cause the temporary opening of the outputs, but the safe functioning of the light curtain will not be compromised.

8.3. Warranty

All appliances are under a 24 month guarantee from the manufacturing date.

Datasensor will not be liable for any damages to persons and things caused by the non-observance of the correct installation modes and device use.

The warranty will not cover damages caused by incorrect installation, incorrect use and accidental causes such as bumps or falls.



In the event of breakdown send the appliance to DATASENSOR S.p.A.

Sales Technical Service

Tel.: +39 051 6765611

Fax.: +39 051 6759324

email: service@datasensor.com

9. TECHNICAL DATA

Power supply:	24 Vdc \pm 20%
Emitter consumption (TX):	70 mA max
Receiver consumption (RX):	100 mA max
Outputs: SE2 SE4	2 PNP output; (2 NPN on request) 2 PNP output; (2 NPN on request); Short-circuit protection 1.5A Signal against short-circuit 0.8A
Output current:	0.7 A max (total for the 2 outputs) 0.5 A max (on single output) 0.25 A max. total from 45 ... 55°
Output voltage:	- 2 V of the power supply voltage T=25°C and 50mA nominal load for canal
Response time:	see the table "Available models"
Emission type:	Infrared (880 nm)
Resolution:	14 mm fingers protection (SE*-14-...) 35 mm hands protection (SE*-35-...) 300... 500mm body protection (SE*-Px-)
Operating distance:	0.2... 6 m (SE*-14-...) 0.2... 15 m (SE*-35-...) 0.5... 50 m (SE2-Px-) 4... 50 m (SE4-Px-) 0.5... 25 m (SE4-Qx-)
Safety range:	Type 2 for SE2-... Type 4 for SE4-...
Auxiliary functions:	Total muting / partial muting / override Auto/Manual Reset
Operating temperature:	- 10...+ 55 °C
Storage temperature:	- 25...+ 70 °C
Humidity:	15...95 % (no condensation)
Electrical protection:	Class 1
Mechanical protection:	IP 65 (EN 60529)
Ambient light rejection:	IEC-61496-2
Vibrations:	amplitude 0,7 mm, frequency 10 ... 55 Hz, 10 s sweep for axis X, Y, Z ; 1octave/min., (EN 60068-2-6)
Shock resistance:	16 ms (ca. 10 G) 1.000 shock for axis (EN 60068-2-29)
Reference standards	EN 61496-1; IEC 61496-2
Housing material:	Painted aluminium (yellow RAL 1028)
Lens material:	PMMA
Connections:	M12 4-pole connector for TX M12 8-pole connector for RX
Muting signalling device:	Lamp 24 V 3W min. (125 mA) 7W max (300 mA)
Weight:	1.2 Kg max./m of total height

10. LIST OF THE AVAILABLE MODELS

Model	Length of the sensitive area	Length of the controlled area	Number of beams	Resolution (mm)	Response time (msec)	Operating distance (m)
SE2-35-015-PP-W	147	187	8	35	15	0.2...15
SE2-35-030-PP-W	294	334	16	35	17	0.2...15
SE2-35-045-PP-W	441	481	24	35	18	0.2...15
SE2-35-060-PP-W	588	628	32	35	20	0.2...15
SE2-35-075-PP-W	735	775	40	35	22	0.2...15
SE2-35-090-PP-W	882	922	48	35	23	0.2...15
SE2-35-105-PP-W	1029	1069	56	35	25	0.2...15
SE2-35-120-PP-W	1176	1216	64	35	27	0.2...15
SE2-35-135-PP-W	1323	1363	72	35	28	0.2...15
SE2-35-150-PP-W	1470	1510	80	35	30	0.2...15
SE2-35-165-PP-W	1617	1657	88	35	32	0.2...15
SE2-P2-050-PP-W	515	n.a.	2	515	14	0.5...50
SE2-P3-080-PP-W	815	n.a.	3	415	14	0.5...50
SE2-P4-090-PP-W	915	n.a.	4	315	14	0.5...50
SE2-P4-120-PP-W	1215	n.a.	4	415	14	0.5...50
SE4-35-015-PP-W	147	187	8	35	15	0.2...15
SE4-35-030-PP-W	294	334	16	35	17	0.2...15
SE4-35-045-PP-W	441	481	24	35	18	0.2...15
SE4-35-060-PP-W	588	628	32	35	20	0.2...15
SE4-35-075-PP-W	735	775	40	35	22	0.2...15
SE4-35-090-PP-W	882	922	48	35	23	0.2...15
SE4-35-105-PP-W	1029	1069	56	35	25	0.2...15
SE4-35-120-PP-W	1176	1216	64	35	27	0.2...15
SE4-35-135-PP-W	1323	1363	72	35	28	0.2...15
SE4-35-150-PP-W	1470	1510	80	35	30	0.2...15
SE4-35-165-PP-W	1617	1657	88	35	32	0.2...15
SE4-P2-050-PP-W	515	n.a.	2	515	14	4...50
SE4-P3-080-PP-W	815	n.a.	3	415	14	4...50
SE4-P4-090-PP-W	915	n.a.	4	315	14	4...50
SE4-P4-120-PP-W	1215	n.a.	4	415	14	4...50
SE4-Q2-050-PP-W	515	n.a.	2	515	14	0.5...25
SE4-Q3-080-PP-W	815	n.a.	3	415	14	0.5...25
SE4-Q4-090-PP-W	915	n.a.	4	315	14	0.5...25
SE4-Q4-120-PP-W	1215	n.a.	4	415	14	0.5...25
SE4-14-015-PP-W	147	161	21	14	18	0.2...6
SE4-14-030-PP-W	294	308	42	14	22	0.2...6
SE4-14-045-PP-W	441	455	63	14	26	0.2...6
SE4-14-060-PP-W	588	602	84	14	31	0.2...6
SE4-14-075-PP-W	735	749	105	14	35	0.2...6

11. OVERALL DIMENSIONS

All the reported dimensions are in mm.

RECEIVER

EMITTER

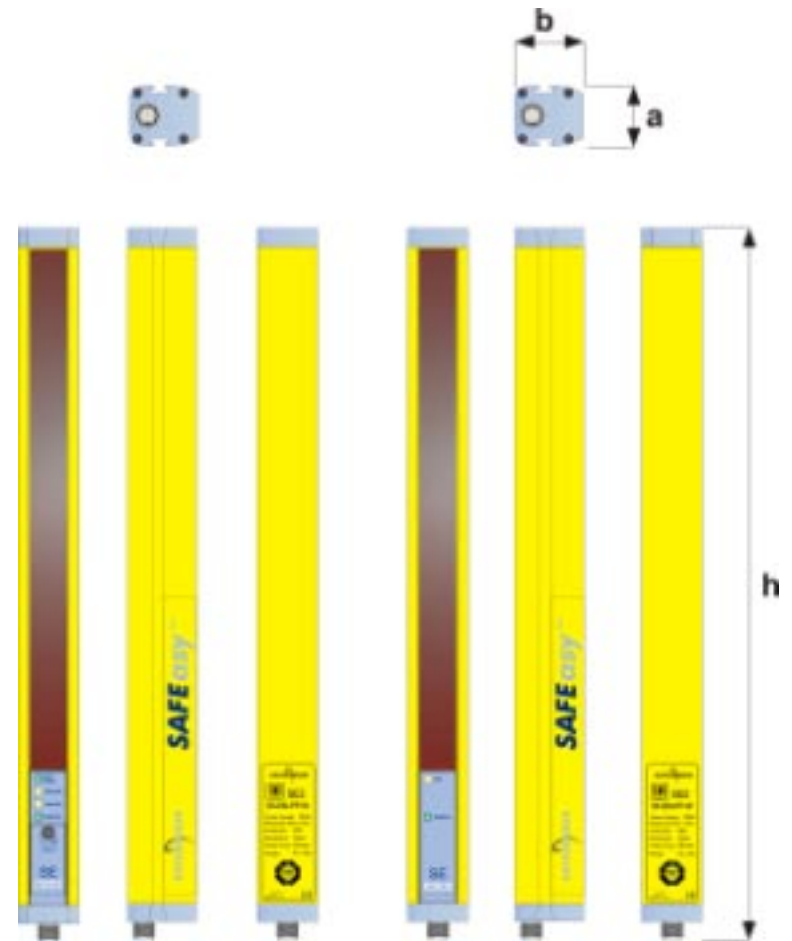

Available models:

MODEL	a x b (mm)	h (mm)
SE2-35-015-PP-W	35 x 40	256
SE2-35-030-PP-W	35 x 40	403
SE2-35-045-PP-W	35 x 40	550
SE2-35-060-PP-W	35 x 40	697
SE2-35-075-PP-W	35 x 40	844
SE2-35-090-PP-W	35 x 40	991
SE2-35-105-PP-W	35 x 40	1138
SE2-35-120-PP-W	35 x 40	1285
SE2-35-135-PP-W	35 x 40	1432
SE2-35-150-PP-W	35 x 40	1579
SE2-35-165-PP-W	35 x 40	1726
SE2-P2-050-PP-W	35 x 40	652
SE2-P3-080-PP-W	35 x 40	952
SE2-P4-090-PP-W	35 x 40	1052
SE2-P4-120-PP-W	35 x 40	1342
SE4-35-015-PP-W	35 x 40	256
SE4-35-030-PP-W	35 x 40	403
SE4-35-045-PP-W	35 x 40	550
SE4-35-060-PP-W	35 x 40	697
SE4-35-075-PP-W	35 x 40	844
SE4-35-090-PP-W	35 x 40	991
SE4-35-105-PP-W	35 x 40	1138
SE4-35-120-PP-W	35 x 40	1285
SE4-35-135-PP-W	35 x 40	1432
SE4-35-150-PP-W	35 x 40	1579
SE4-35-165-PP-W	35 x 40	1726
SE4-P2-050-PP-W	35 x 40	652
SE4-P3-080-PP-W	35 x 40	952
SE4-P4-090-PP-W	35 x 40	1052
SE4-P4-120-PP-W	35 x 40	1352
SE4-Q2-050-PP-W	35 x 40	652
SE4-Q3-080-PP-W	35 x 40	952
SE4-Q4-090-PP-W	35 x 40	1052
SE4-Q4-120-PP-W	35 x 40	1352
SE4-14-015-PP-W	35 x 40	256
SE4-14-030-PP-W	35 x 40	403
SE4-14-045-PP-W	35 x 40	550
SE4-14-060-PP-W	35 x 40	697
SE4-14-075-PP-W	35 x 40	844