



DS1500 miniaturization allows easy integration into OEM equipment and automatic machinery. The high scan rate and sophisticated electronic design effectively addresses difficult reading conditions.

Availability of embedded ACB™ (Advanced Code Builder) reconstruction SW algorithm allows consistent decoding of damaged or mis-applied labels (resulting in high tilt angles).

DS1500 installation and configuration is easy and simple thanks to compact size and to the new test operating mode with bar-graph. Test mode is activated by means of a pushbutton on the scanner (external PC not required) and the led bargraph shows the real time read percentage. This feature increases the scanner ease of installation and re-positioning during product changeovers in automated machinery.

DS1500 operates at a speed up to 1200scan/s, extending the application range also to high speed document handling, paper inserting, label rewinding and packaging machines.

Additionally, the scanner motor can be switched ON and OFF via SW command. This feature is useful in very low throughput application or when the machine sits idle for long periods. A simple software command allows a prompt restoration of full operation when needed.



Compact Dimensions

1200 scans/s

Test mode with bar-graph

44 g
Lightweight



IDENTIFICATION

FEATURES

- Extremely compact dimensions (40 x 30 x 22mm)
- Up to 1200 scan/s
- ACB™ (Advanced Code Builder) reconstruction
- Ease of use - Test mode with bar-graph
- Motor ON/OFF SW control
- Selectable RS232/485 serial link
- IP65 rugged industrial housing

APPLICATIONS

- OEM integration
- Chemical and biomedical analysis machines
- Document handling
- Print & Apply systems
- Packaging machines
- ATL (Automated Tape Library)



TECHNICAL DATA

ELECTRICAL CHARACTERISTICS	
Power supply	5 VDC
Power consumption	2 W max.
MECHANICAL CHARACTERISTICS	
Dimensions	40 x 30 x 22 mm
Weight	44 g without cable
Case material	Zama (zinc, aluminum, magnesium alloy)
PERFORMANCE	
Light source	Visible laser diode (658 nm)
Max. Resolution	0,15 mm
Scanning speed	1200 scans/s o 800 scans/s (SW selectable)
Max. Reading distance	240 mm / 9.45 in (on codes with 0.50 mm/20 mils resolution)
Max. Depth of field	200 mm / 7.87 in (on codes with 0.50 mm/20 mils resolution)
Aperture angle	60°
Readable codes	All main linear bar code symbologies
Reconstruction software acb™	(Advanced Code Builder) integrated
Multilabel reading	Up to 6 different codes readable in the same phase
User interface	Pushbutton, 5 LEDs (scanner status/performance monitor)
Led indicators	'Power on/100%', 'Good Read/80%', 'Ext. Trig./60%', 'TX Data/40%', 'Laser On/20%'
Input/output signals	1 digital Input + 2 programmable digital outputs
Programming method	Via serial port (Winhost™)
Operating modes	On Line; Serial On Line; Automatic; Continuous; Test
Connectivity	2 x RS232 o 1 x RS485 (full o half duplex) SW selectable
Baud rate	Up to 115,2 Kbaud
Laser classification	Classe 2 - EN 60825-1, Class II - CDRH
Laser control	Safety system to turn laser off in cases of motor slowdown or failure
Motor control	On/Off via SW command
ENVIRONMENT	
Operating temperature	0 ÷ 45°C
Storage temperature	-20 ÷ 70 °C
Humidity	90% non condensing
Vibration resistance	IEC 68-2-6 test FC 1.5 mm; 10 to 55 Hz; 2 hours on each axis 2.5 W max; 2.0 W typ.
Shock resistance	IEC 68-2-27 test EA 30 G; 11 ms; 3 shocks on each axis
Protection class	IP65

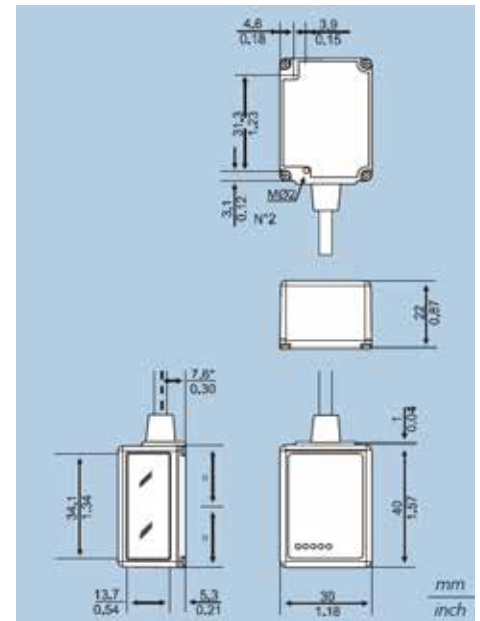

Dimensions

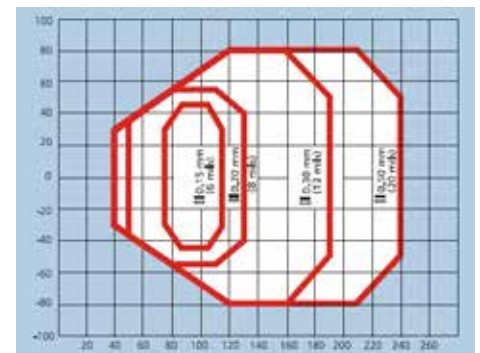

Reading diagram

MODELS

P/N	DESCRIPTION
939201000	DS1500-1100 ST-RES,RS232+RS485,LIN,DIR
939201001	DS1500-2100 HI-RES,RS232+RS485,LIN,DIR

ACCESSORIES

P/N	DESCRIPTION
93A201101	GFC-TC1100 80 DEG.MIRROR
93ACC1670	TC1100 REFERENCE MANUAL+CONFIGURATOR SW
93ACC1780	ADP-015 ADAPTER 25P 10-30VDC
93ACC1771	DS1500 CONF. SW+RF MANUAL DOCS
93A201030	GFC-2200 90° READING DEVICE
93ACC1040	DC5-2200 DC CONVERTER 4-30 VDC TO 5 V